

**MX150 MAT SEAL / UNSEALED RECEPTACLE CRIMP TERMINAL**

**1.0 SCOPE**

This specification details the crimping information and common practices of general crimps for the Molex MX150 Mat Seal / Unsealed Receptacle Terminal. Please refer to sales drawing SD-33012-002 for additional part information. The information in this document is for reference and benchmark purposes only. Customers are required to complete their own validation testing if tooling and/or wire is different than what is shown in this specification.

All measurements are in millimeters and Newtons unless specified otherwise.

Terminals shown in this document are generic representations. They are not intended to be an image of any terminal listed in the scope.

**2.0 PRODUCT DESCRIPTION**

**DEFINITION OF TERMS:**

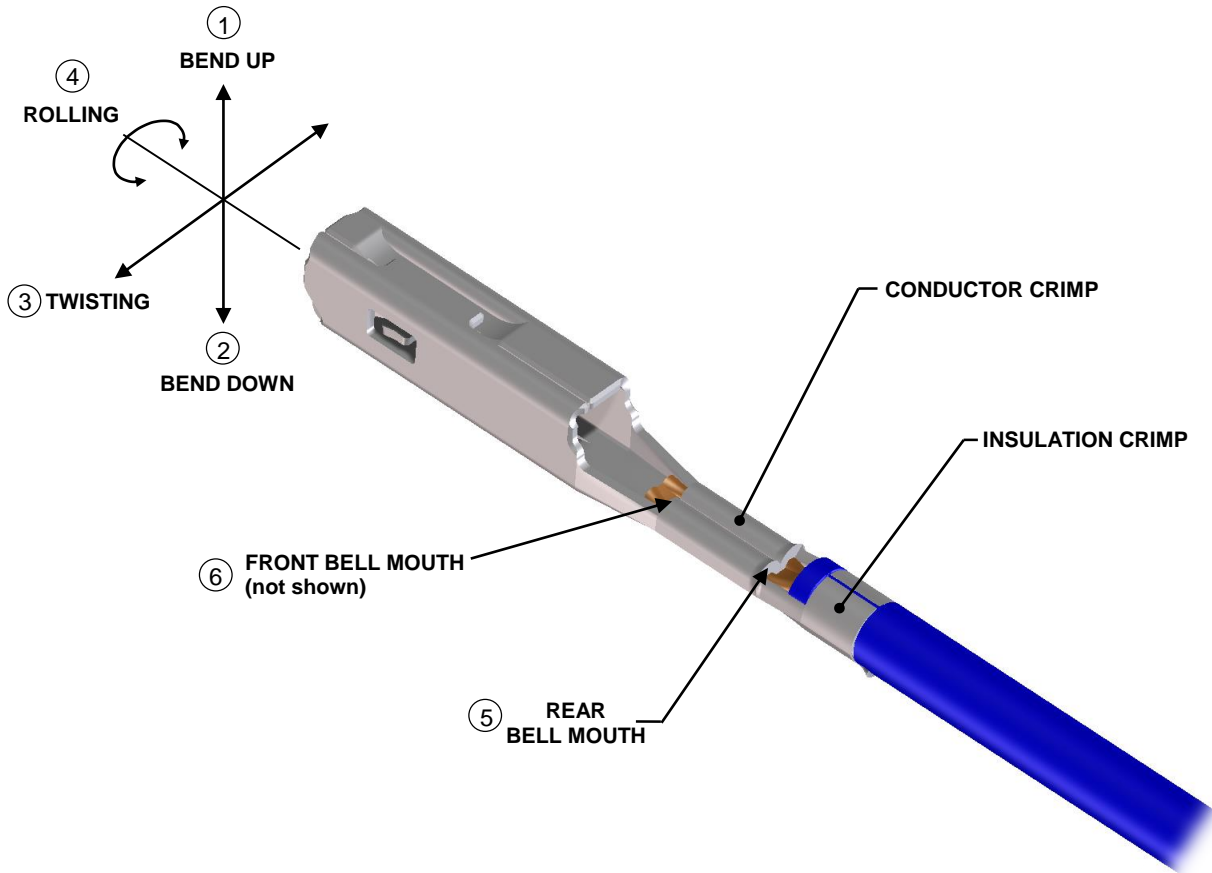


Figure 1

REVISION: <b>E2</b>	ECR/ECN INFORMATION: ECM No: 610323 DATE: 01/11/2019	<b>MX150 MAT SEAL / UNSEALED RECEPTACLE APPLICATION SPECIFICATION</b>		SHEET No. <b>1 of 24</b>
DOCUMENT NUMBER: <b>AS-33012-002</b>		CREATED BY: <b>A.Proffitt</b>	CHECKED BY: <b>A.Dhir</b>	APPROVED BY: <b>T.Smith</b>

**DEFINITIONS OF TERMS (CONT.):**

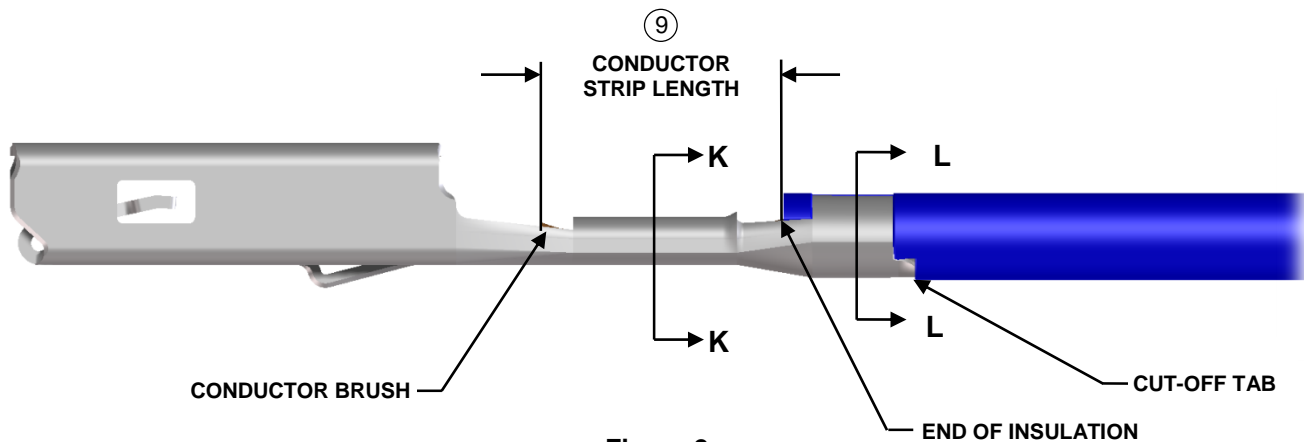


Figure 2

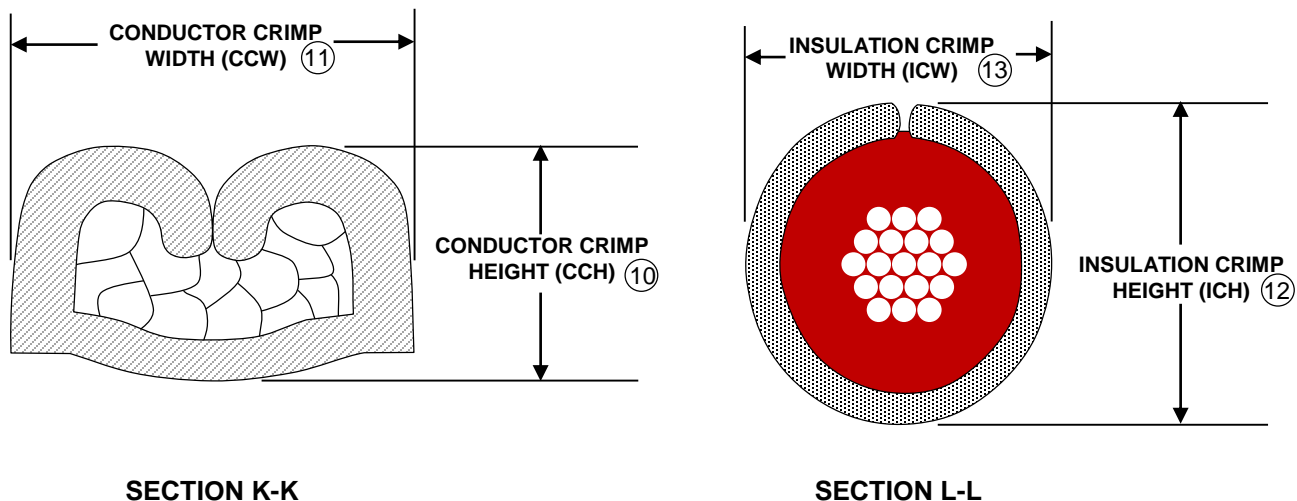
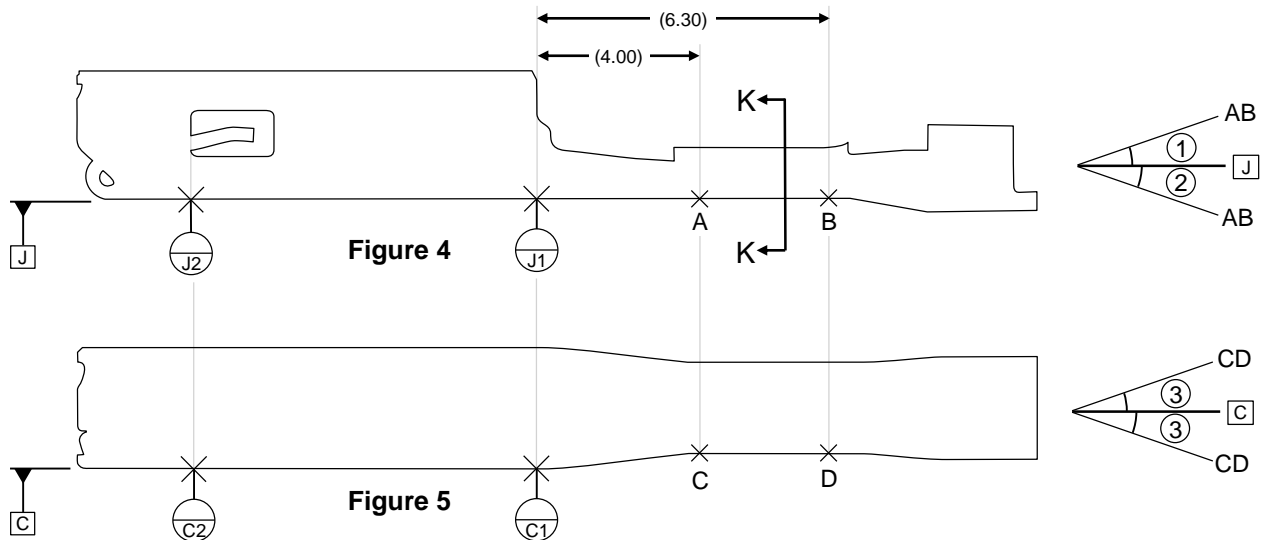


Figure 3

REVISION: <b>E2</b>	ECR/ECN INFORMATION: ECM No: 610323 DATE: 01/11/2019	<b>MX150 MAT SEAL / UNSEALED RECEPTACLE APPLICATION SPECIFICATION</b>		SHEET No. <b>2 of 24</b>
DOCUMENT NUMBER: <b>AS-33012-002</b>		CREATED BY: A.Proffitt	CHECKED BY: A.Dhir	APPROVED BY: T.Smith

**STRAIGHTNESS MEASUREMENTS**

The crimping process may result in some bending between the conductor crimp and the terminal box. This bending must not exceed the limits shown in Table 3.



**BEND UP/DOWN** ① ②

To measure bend up/down, establish datum J as shown in Figure 4 then measure the angle of the line defined by points A and B with respect to the datum. Positive angles are defined as bend up and negative angles are defined as bend down, see Figure 4.

**TWISTING** ③

To measure twisting, establish datum C as shown in Figure 5, then measure the angle of the line defined by points C and D with respect to the datum, see Figure 5.

**ROLLING** ④

To measure rolling, cross section the part at section K-K (see Figure 4), then clamp the part in a vice as shown in Figure 6. Using a shadowgraph, focus the graph to section H-H and establish line M-M as the top of the terminal box. With line M-M established, refocus the graph to section J-J. Measure the angle of the line defined by points E and F with respect to line M-M.

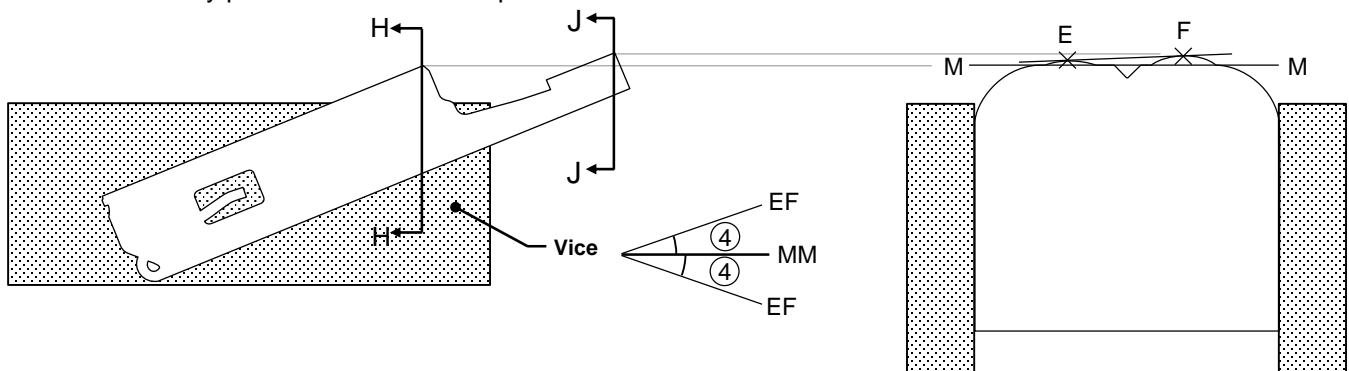
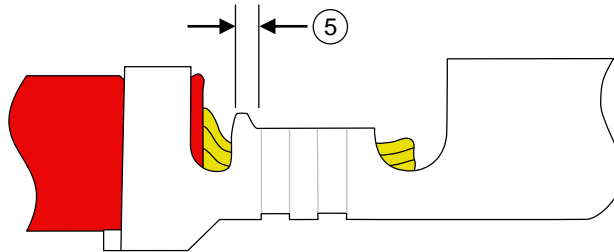


Figure 6

REVISION: <b>E2</b>	ECR/ECN INFORMATION: ECM No: 610323 DATE: 01/11/2019	<b>MX150 MAT SEAL / UNSEALED RECEPTACLE APPLICATION SPECIFICATION</b>		SHEET No. <b>3 of 24</b>
DOCUMENT NUMBER: <b>AS-33012-002</b>	CREATED BY: <b>A.Proffitt</b>	CHECKED BY: <b>A.Dhir</b>	APPROVED BY: <b>T.Smith</b>	

**BELLMOUTH (FLARE) ⑤⑥**

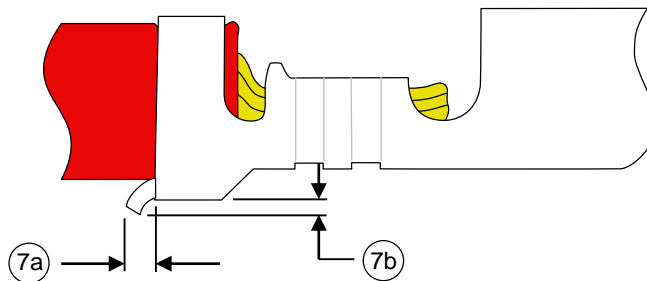
The flare that is formed on the edge of the conductor crimp acts as a funnel for the wire strands. This funnel reduces the possibility that a sharp edge on the conductor crimp will cut or nick the wire strands. A rear bellmouth is required on the conductor crimp. A front bellmouth is optional. Caution: Excessively large bellmouths will reduce crimp area and reduce pull forces. See Table 3 for bellmouth specifications.



**Figure 7**

**CUT- OFF TAB ⑦**

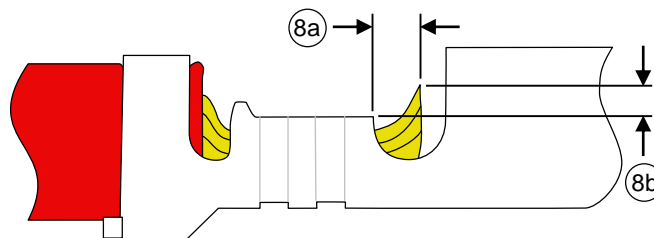
This is the material that protrudes outside the insulation crimp after the terminal is separated from the carrier strip. A cut-off tab that is too long may expose a terminal outside the housing and it may fail electrical spacing requirements. In most situations, a tool is setup to provide a cut-off tab that shall not exceed the value indicated in Table 3. CAUTION: Burrs on the cut-off tab are not allowed as they have the potential to cut mat seals.



**Figure 8**

**CONDUCTOR BRUSH ⑧**

The conductor brush is made up of the wire strands that extend past the conductor crimp on the contact side of the terminal. This helps ensure that mechanical compression occurs over the full length of the conductor crimp. The conductor brush should not extend into the contact area or above the conductor crimp/transition wall height (whichever is tallest), see Figure 9 and Table 3. CAUTION: Excessive conductor brush extended above the transition/crimp area can cause terminal retention issues inside plastic cavity and potentially could compromise/tear the glands of the mat seal.



**Figure 9**

REVISION:	ECR/ECN INFORMATION:	<b>MX150 MAT SEAL / UNSEALED RECEPTACLE APPLICATION SPECIFICATION</b>		SHEET No.
<b>E2</b>	ECM No: 610323 DATE: 01/11/2019			<b>4 of 24</b>
DOCUMENT NUMBER:	CREATED BY:	CHECKED BY:	APPROVED BY:	
<b>AS-33012-002</b>	<b>A.Proffitt</b>	<b>A.Dhir</b>	<b>T.Smith</b>	

## CONDUCTOR STRIP LENGTH ⑨

The strip length is determined by measuring the exposed conductor strands after the insulation is removed. The strip length determines the conductor brush length when the end-of-insulation position is centered in the transition area between conductor and insulation crimps. See Table 3 for the length requirement

**CAUTION:** Care must be taken to ensure that all conductor strands are equal in length (no diagonally cut strands). No scratched or missing strands are permitted. The insulation cut must be uniform (no diagonally cut insulation and no extrusions of insulation). Care must also be taken not to leave indentations on the wire strands during the strip and cut operation as this can compromise the effectiveness of the mat seal and can result in leaks.

## CONDUCTOR CRIMP

This is the metallurgical compression of a terminal around the wire's conductor. This connection creates a common electrical path with low resistance and high current carrying capabilities. The crimp seam shall not be open and all conductor strands must be contained within the conductor crimp.

## CONDUCTOR CRIMP HEIGHT ⑩

The conductor crimp height is measured from the top surface of the formed crimp to the bottom most radial surface. Do not include the extrusion points in this measurement. Measuring crimp height is a quick, non-destructive way to help ensure the correct metallurgical compression of a terminal around the wire's conductor and is an excellent attribute for process control. The crimp height specification is typically set as a balance between electrical and mechanical performance over the complete range of wire stranding and coatings, and terminal materials and plating. Although it is possible to optimize a crimp height to individual wire strands and terminal plating, one crimp height specification is normally created. See Table 2 for crimp height specifications.

## INSULATION CRIMP HEIGHT ⑫

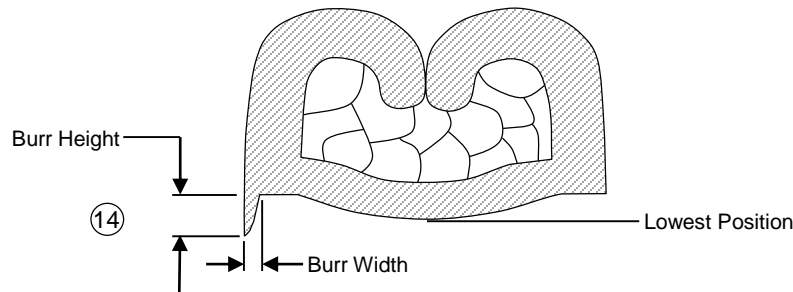
Insulation crimp heights are specified in Table 2. MX150 Mat Seal / Unsealed Receptacle Terminals are designed to accommodate multiple wire sizes. Although within the terminal range, an insulation grip may not completely surround the wire, an acceptable insulation crimp will still be provided. Evaluate the insulation section by cutting the wire flush with the back of the terminal. Once the optimum setting for the application is determined, it is important to document the insulation crimp height. Then, as part of the setup procedure, the operator can check the crimp height.

REVISION:  <b>E2</b>	ECR/ECN INFORMATION: ECM No: <b>610323</b> DATE: <b>01/11/2019</b>	<b>MX150 MAT SEAL / UNSEALED RECEPTACLE APPLICATION SPECIFICATION</b>	SHEET No.  <b>5 of 24</b>
DOCUMENT NUMBER:  <b>AS-33012-002</b>	CREATED BY:  <b>A.Proffitt</b>		CHECKED BY:  <b>A.Dhir</b>

**CONDUCTOR ANVIL FLASH (EXTRUSIONS/BURR) (14)**

These are the small flares that form on the bottom of the conductor crimp resulting from the clearance between the punch and anvil tooling. If the anvil is worn or the terminal is over-crimped, excessive extrusion can result.

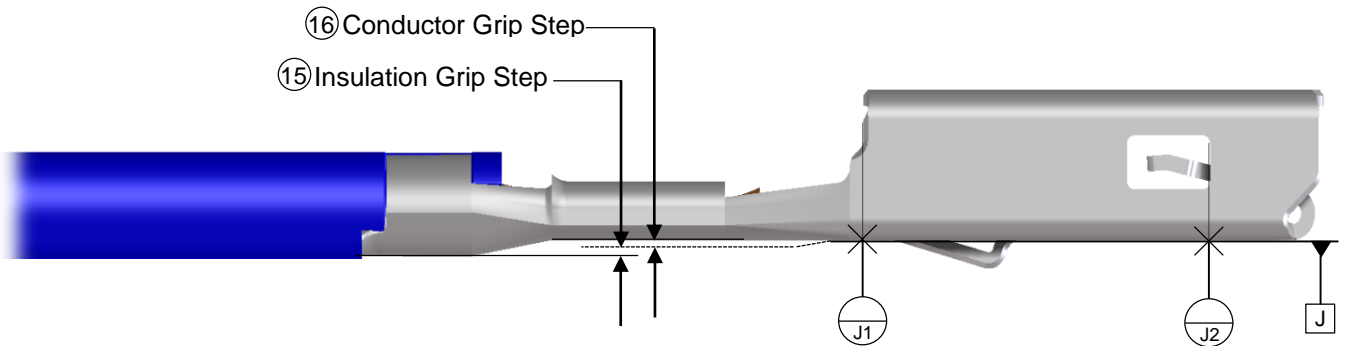
An uneven extrusion may also result if the punch and anvil are misaligned, if the feed is misadjusted or if there is insufficient or excessive terminal drag. CAUTION: Anvil Flash has the potential to damage mat seals and should be maintained within specifications (see Figure 10 and Table 3). Note: Anvil Flash (Burr) may not extend below the bottom of the crimp.



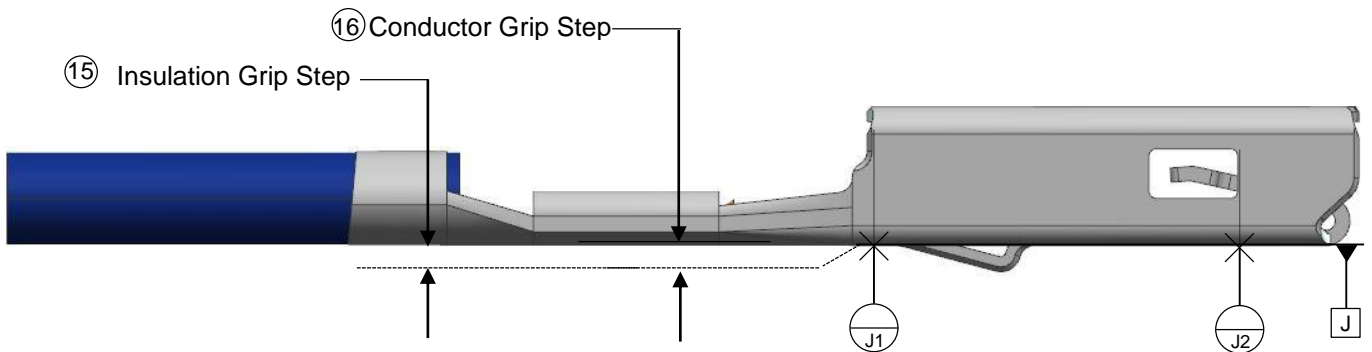
**Figure 10**

**INSULATION GRIP STEP (15)**

The insulation grip step is the designed offset between the conductor grip and the insulation grip which must be met by the crimp process (see Figure 11a, 11b and Table 3).

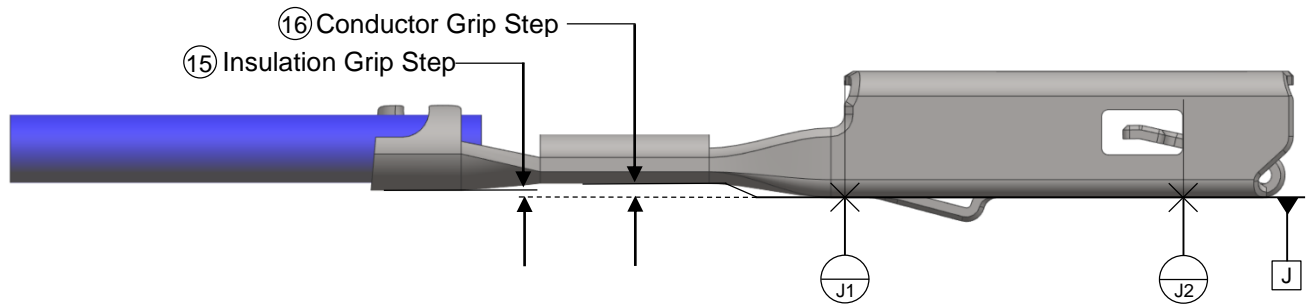


**Figure 11a – 14 & 18 GRIP CODE TERMINALS**



**Figure 11b – 22 GRIP CODE TERMINAL**

REVISION: <b>E2</b>	ECR/ECN INFORMATION: ECM No: 610323 DATE: 01/11/2019	<b>MX150 MAT SEAL / UNSEALED RECEPTACLE APPLICATION SPECIFICATION</b>		SHEET No. <b>6 of 24</b>
DOCUMENT NUMBER: <b>AS-33012-002</b>	CREATED BY: <b>A.Proffitt</b>	CHECKED BY: <b>A.Dhir</b>	APPROVED BY: <b>T.Smith</b>	



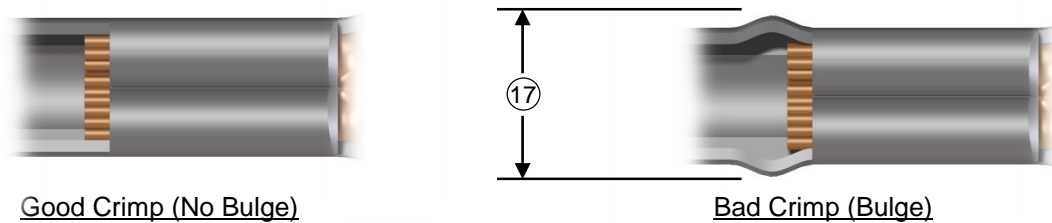
**Figure 11c – M3 GRIP CODE TERMINAL**

**END-OF-INSULATION POSITION**

This is the location of the insulation in relation to the transition area between the conductor and insulation crimps. Equal amounts of the conductor strands and insulation needs to be visible in the transition area. The end-of insulation position ensures that the insulation is crimped along the full length of the insulation crimp and that no insulation gets crimped under the conductor crimp. The end-of-insulation position is set by the wire stop and strip length for bench applications. For automatic wire processing applications the end-of-insulation position is set by the in/out press adjustment (see Figure 2).

**CRIMP BULGE (17)**

Caution needs to be taken with the crimp tooling to prevent a bulge in the transition area during crimping. The transition should generally flow smoothly from the conductor crimp to the terminal box. Any bulge must not exceed the width shown in Table 3. See Figure 12 for an example of crimp bulge.



**Figure 12**

**BOX DEFORMATION**

Care must be taken to ensure that the terminal box is not deformed during crimping and handling. Any deformation of the terminal box must not exceed the tolerances specified in sales drawing SD-33012-002.

REVISION: <b>E2</b>	ECR/ECN INFORMATION: ECM No: 610323 DATE: 01/11/2019	<b>MX150 MAT SEAL / UNSEALED RECEPTACLE APPLICATION SPECIFICATION</b>		SHEET No. <b>7 of 24</b>
DOCUMENT NUMBER: <b>AS-33012-002</b>		CREATED BY: <b>A.Proffitt</b>	CHECKED BY: <b>A.Dhir</b>	APPROVED BY: <b>T.Smith</b>

## 3.0 PRODUCT SPECIFICATIONS

Table 1

Terminal Family	Gender	Sealing	Plating	Special Characteristics	Grip Code	Wire Size	Insulation Diameter Range
MX150	Receptacle	Mat Seal ONLY	Sn	Standard Performance Tin	M3	0.35 – 0.50mm <sup>2</sup>	1.20 – 1.70
			Sn	High Performance Tin			
			Ag	High Performance Silver			
			Au	High Performance Gold			
		Mat Seal OR Unsealed	Sn	High Performance Tin	22	22AWG 0.35 – 0.50mm <sup>2</sup> ⓘ	1.20 – 1.70
			Ag	High Performance Silver			
			Au	High Performance Gold			
			Sn	High Performance Tin	18	20 – 18 AWG 0.75 – 1.00mm <sup>2</sup>	1.60 – 2.54
			Ag	High Performance Silver			
			Au	High Performance Gold			
			Sn	High Performance Tin	14	16 – 14AWG 1.50 – 2.00mm <sup>2</sup>	2.10 – 2.70
			Ag	High Performance Silver			
Au	High Performance Gold						

REVISION: <b>E2</b>	ECR/ECN INFORMATION: ECM No: <b>610323</b> DATE: <b>01/11/2019</b>	<b>MX150 MAT SEAL / UNSEALED RECEPTACLE APPLICATION SPECIFICATION</b>	SHEET No. <b>8 of 24</b>
DOCUMENT NUMBER: <b>AS-33012-002</b>	CREATED BY: <b>A.Proffitt</b>	CHECKED BY: <b>A.Dhir</b>	APPROVED BY: <b>T.Smith</b>





# APPLICATION SPECIFICATION

Table 2

Molex Product Attribute			Validated Wire		Conductor Barrel		Insulation Barrel		MIN PULL OUT FORCE			
Grip Code	Special Characteristics	Sealing	Wire Type	Wire Size	CCH ± 0.05	CCW ± 0.10	ICH ± 0.10	ICW ± 0.10				
M3	High Performance Silver High Performance Gold	Mat Seal ONLY	PSA FTP 00949_10_00766 ④	0.35 mm <sup>2</sup>	1.08±0.03	1.60	1.75	2.00	60			
			PSA FTP 00949_10_00767 ④	0.50 mm <sup>2</sup>	1.15		2.10±0.05			70		
	Standard Performance Tin High Performance Tin High Performance Silver High Performance Gold		T3ZHID FLR91X-A-XLPO⑤	0.35mm <sup>2</sup>	1.05±0.03		1.75		50			
				0.50mm <sup>2</sup>	1.10		1.90		75			
			JASO D611 (AVSS)	0.50mm <sup>2</sup>	1.10		2.00±0.05		88.3			
	AVSSB											
	JASO D608 (AVSSH)											
JASO D611 (AESSXf)												
High Performance Tin				1.90								
22	High Performance Tin High Performance Silver High Performance Gold	Mat Seal OR Unsealed	M1L-123A4 (TXL)	22AWG	1.00	1.60	1.85	1.90	50			
			WSK-1A348-A2	0.35mm <sup>2</sup> ①	0.95		1.70		50			
			M1L-126A1	0.50mm <sup>2</sup> ①	1.10		1.80		75			
			JASO D611 (AVSS)	0.50mm <sup>2</sup> ①	1.10		1.85		75			
18	High Performance Tin High Performance Silver High Performance Gold	Mat Seal OR Unsealed	M1L-123A4 (TXL)	20AWG	1.15	2.15	1.90	2.10	75			
			HIFLON ②	20AWG	1.15		1.90	2.10	75			
			SAE J1128 (GXL)	20AWG	1.15		2.00	2.30	75			
			M1L-123A4 (TXL)	18AWG	1.25		2.00	2.30	90			
			SAE J1128 (GXL)	18AWG	1.25		2.40	2.60	90			
			EXRAD BLOCKED	0.75mm <sup>2</sup>	1.15		2.30±0.05	2.10	90			
			JASO D611 (AESSXf)	0.75mm <sup>2</sup>	1.25		2.30±0.05	2.10	90			
	M1L-126A1 FLR91X-A-XLPO⑤ EXRAD UNBLOCKED											
	PSA FTP 00949_10_00768 ④											
	High Performance Silver High Performance Gold High Performance Tin High Performance Silver High Performance Gold High Performance Silver High Performance Gold	Mat Seal OR Unsealed	JASO D611 (AVSS)	0.85 mm <sup>2</sup>	1.30	2.45	2.30±0.05	2.30	127.5			
			M1L-126A1	1.00mm <sup>2</sup>	1.30		2.35±0.05	2.30	120			
			FLR91X-A-XLPO⑤				1.35					
			PSA FTP 00949_10_00769 ④	1.00mm <sup>2</sup>	1.35		2.30±0.05	2.30	115			
14			High Performance Tin High Performance Silver High Performance Gold	Mat Seal OR Unsealed	M1L-123A4 (TXL)		16AWG	1.35	2.45	2.40	2.60	120
					M1L-135A1 (UTX)		14AWG	1.65		2.70	2.60	180
	M1L-123A4 (TXL)	14AWG			1.65	2.95±0.05	2.70±0.05	180				
	JASO D611 (AVSS)	1.25mm <sup>2</sup>			1.35	2.51	2.63	176.5				
	JASO D611 (AESSXf)											
	JASO D611 (AVS)	1.50mm <sup>2</sup>	1.40		2.68±0.05	2.68±0.05	150					
	M1L-126A1 FLR91X-A-XLPO⑤ EXRAD BLOCKED EXRAD UNBLOCKED											
	PSA FTP 00949_10_00770 ④							1.50mm <sup>2</sup>		1.45	2.50±0.05	155
	High Performance Silver High Performance Gold	JASO D611 (AVSS)	2.00mm <sup>2</sup>		1.60	2.90	2.70±0.05	180				
High Performance Tin High Performance Silver High Performance Gold High Performance Silver High Performance Gold	PSA FTP 00949_10_00771 ④	2.00mm <sup>2</sup>	1.55	195								

REVISION:	ECR/ECN INFORMATION:	<b>MX150 MAT SEAL / UNSEALED RECEPTACLE APPLICATION SPECIFICATION</b>			SHEET No.
<b>E2</b>	ECM No: 610323 DATE: 01/11/2019				<b>9 of 24</b>
DOCUMENT NUMBER:	CREATED BY:	CHECKED BY:	APPROVED BY:		
<b>AS-33012-002</b>	<b>A.Proffitt</b>	<b>A.Dhir</b>	<b>T.Smith</b>		



# APPLICATION SPECIFICATION

The above specifications are guidelines to an optimum crimp.

Crimp heights/widths are applicable for punch/anvil tooling shown in Figures 15 - 23.

**Note: Please refer to the Molex Product and Application Specification for the approved wires and terminals that have been qualified in the specific connector being used. This table does not imply that the terminal and wire combination has been qualified in a Molex connection system.**

Pull force should be measured with no influence from the insulation crimp.

Customers are required to complete their own validation testing if tooling and/or wire is different than what is shown in this specification.

- ① Unsealed applications only
- ② HIFLON specification - Core: Stainless Steel, Ø0.16, 7 strands. Surrounding wire: Nickel plated Copper, 30 strands.
- ③ Wire type construction complies with GM & Ford wire specification; GMW 15626 (11/2012) and ES-AU5T-1A348-AA
- ④ Wire validated following PSA B217050 Rev D specification for gold and silver terminals

REVISION: <b>E2</b>	ECR/ECN INFORMATION: ECM No: <b>610323</b> DATE: <b>01/11/2019</b>	<b>MX150 MAT SEAL / UNSEALED RECEPTACLE APPLICATION SPECIFICATION</b>		SHEET No. <b>10 of 24</b>
DOCUMENT NUMBER: <b>AS-33012-002</b>		CREATED BY: <b>A.Proffitt</b>	CHECKED BY: <b>A.Dhir</b>	APPROVED BY: <b>T.Smith</b>



# APPLICATION SPECIFICATION

Table 3

## Specifications

Balloon #	Feature	Requirement	
1	Bend Up	TYP.	3° MAX
		Grip Code M3	1.5° MAX
2	Bend Down	TYP.	3° MAX
		Grip Code M3	1.5° MAX
3	Twisting	3° MAX	
4	Rolling	3° MAX	
5	Rear Bell Mouth	0.30 – 0.70	
6	Front Bell Mouth	Not Applicable	
7	Cut-Off Tab	a	0.50 MAX
		b	No Burr
8	Conductor Brush	a	0.40 MAX
		b	Not to extend above conductor crimp/transition height
9	Conductor Strip Length	4.70 – 5.60 for reference	
10	Conductor Crimp Height	See Table 2	
11	Conductor Crimp Width	See Table 2	
12	Insulation Crimp Height	See Table 2	
13	Insulation Crimp Width	See Table 2	
14	Conductor Anvil Flash	Burr Height	Not to extend below lowest point on conductor crimp
		Burr Width	0.10 MAX
15	Insulation Grip Step From J1-J2 (see Figure 11a, 11b & 11c)	TYP.	0.30 ± 0.10
		Grip Code 22	0.00 ± 0.10
		Grip Code M3	0.15 ± 0.30
16	Conductor Grip Step From J1-J2 (see Figure 11a & 11b) For M3 Grip Terminals Only	TYP.	0.00 ± 0.10
		Grip Code M3	0.30 ± 0.10
17	Crimp Bulge	2.65 MAX	

REVISION: <b>E2</b>	ECR/ECN INFORMATION: ECM No: <b>610323</b> DATE: <b>01/11/2019</b>	<b>MX150 MAT SEAL / UNSEALED RECEPTACLE APPLICATION SPECIFICATION</b>	SHEET No. <b>11 of 24</b>
DOCUMENT NUMBER: <b>AS-33012-002</b>	CREATED BY: <b>A.Proffitt</b>	CHECKED BY: <b>A.Dhir</b>	APPROVED BY: <b>T.Smith</b>

## 4.0 REFERENCE DOCUMENTS

Reference documentation for general practices is located on the website per the below links:

1. Molex Quality Crimping Handbook [http://www.molex.com/images/products/apptool/qual\\_crimp.pdf](http://www.molex.com/images/products/apptool/qual_crimp.pdf)
2. Molex-Recognizing Good Crimps <http://www.molex.com>, search for Application Tooling

## 5.0 PROCEDURE

### 5.1 GENERAL MEASUREMENT AND EVALUATION REQUIREMENTS

#### Crimp Height Measurement (Anvil Flash Evaluation)

1. Complete tool set-up procedure.
2. Crimp a minimum of 5 samples.
3. Place the flat blade of the crimp micrometer across the center of the dual radii of the conductor crimp. Do not take the measurement near the conductor bell mouth (see Figure 13).
4. Rotate the micrometer dial until the point contacts the bottom most radial surface. If using a caliper, be certain not to measure the conductor anvil flash (extrusions) of the crimp (see Figure 14).

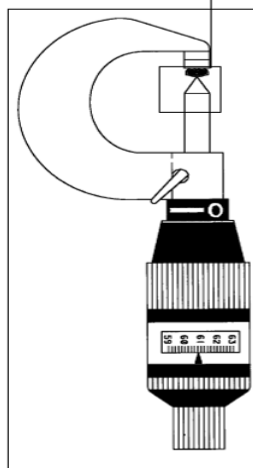
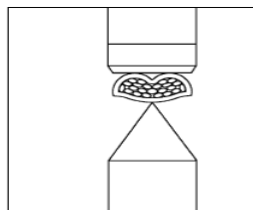


Figure 13

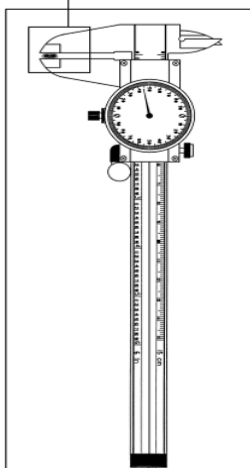
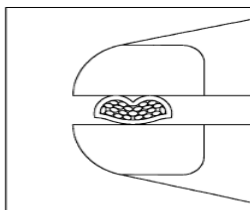
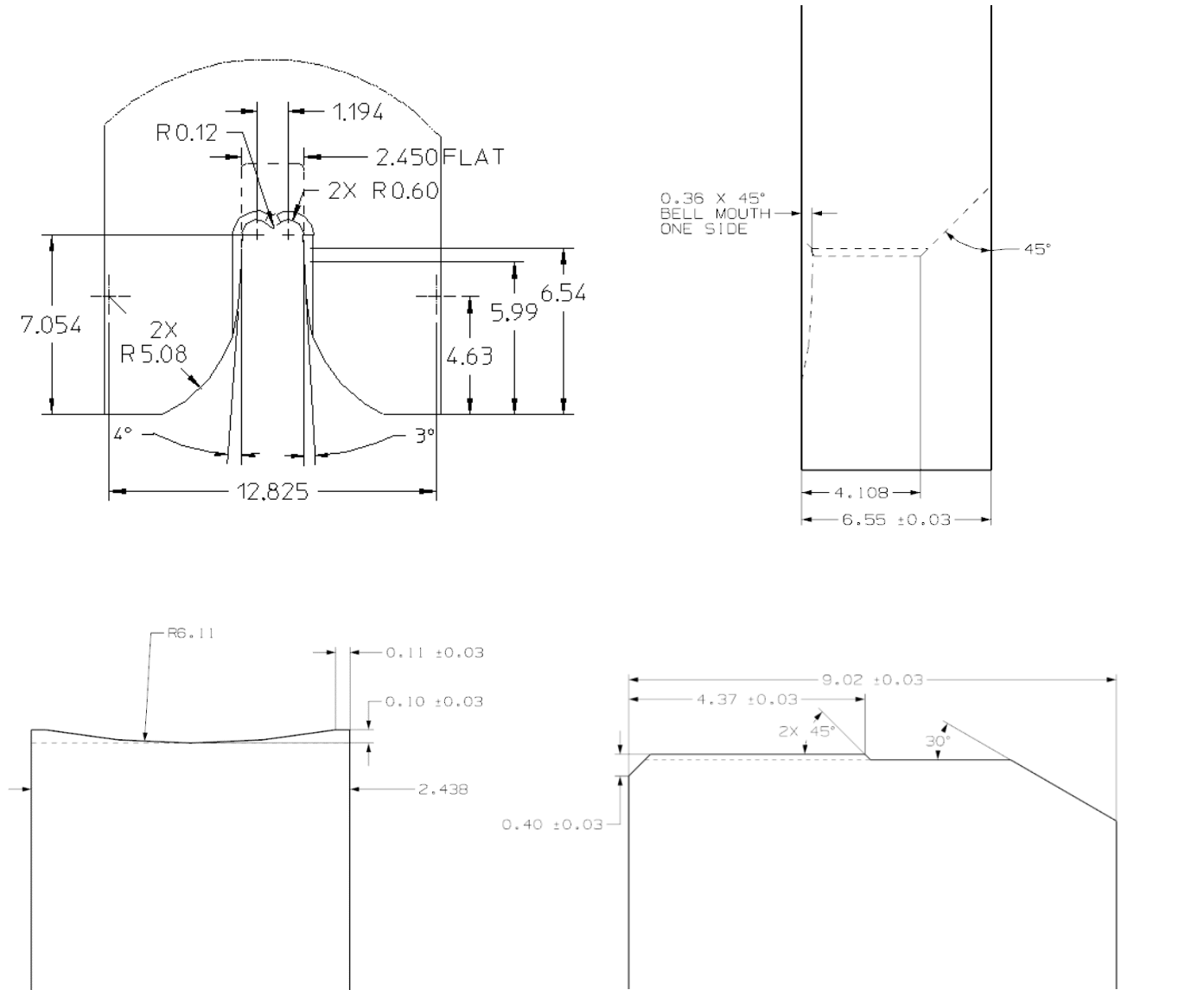


Figure 14

REVISION: <b>E2</b>	ECR/ECN INFORMATION: ECM No: 610323 DATE: 01/11/2019	<b>MX150 MAT SEAL / UNSEALED RECEPTACLE APPLICATION SPECIFICATION</b>		SHEET No. <b>12 of 24</b>
DOCUMENT NUMBER: <b>AS-33012-002</b>	CREATED BY: <b>A.Proffitt</b>	CHECKED BY: <b>A.Dhir</b>	APPROVED BY: <b>T.Smith</b>	

**6.0 CRIMP TOOLING GEOMETRY**

The crimp tooling information shown on the following pages defines the tooling used by Molex to perform validation testing, to establish recommended crimp height and widths. The user is responsible for validating crimp performance based on tooling, equipment and wire that is being used.

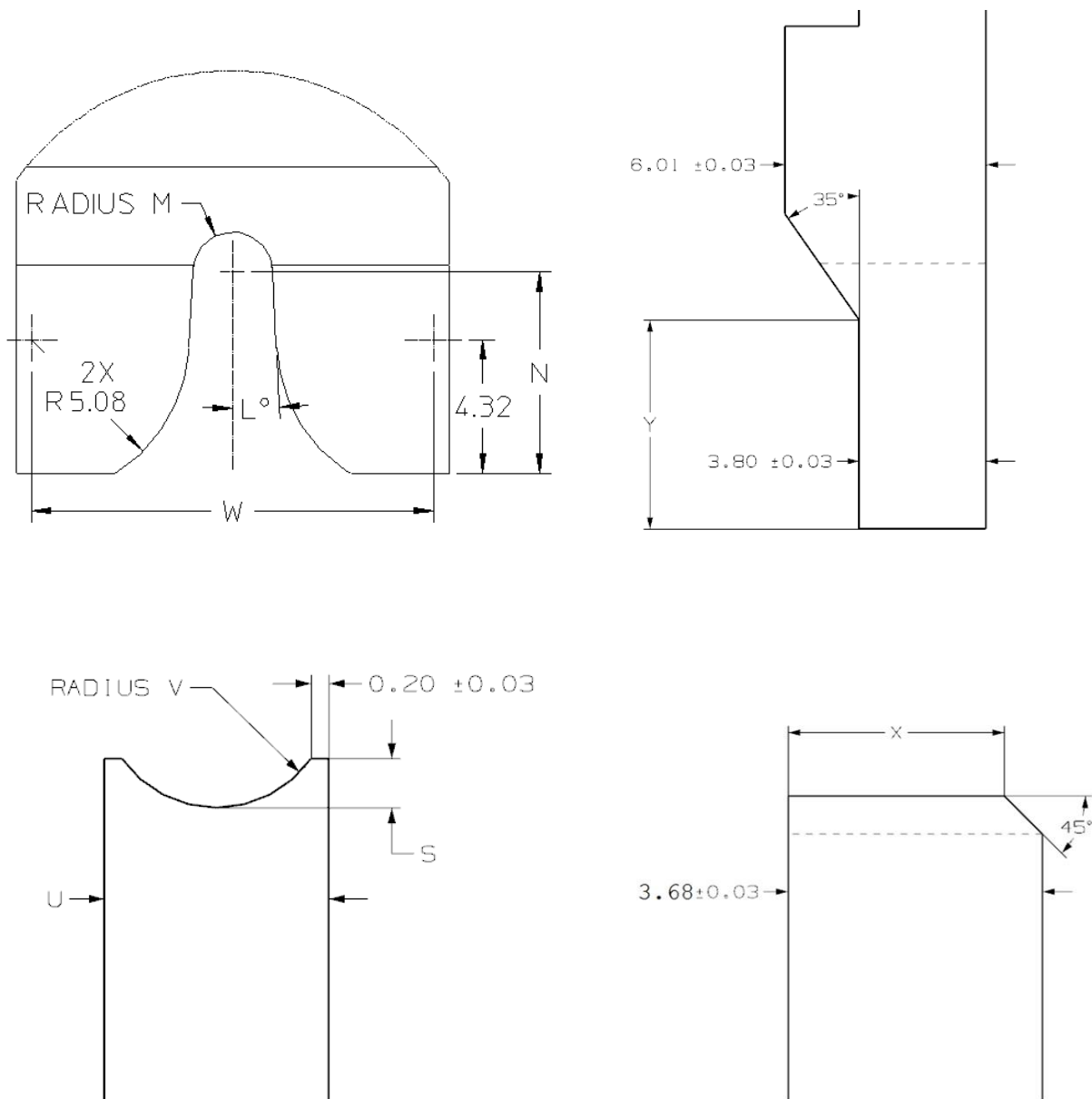


**Figure 15**

The conductor punch (top), and conductor anvil (bottom) are shown for Grip Codes 14 only.

GENERAL TOLERANCES (UNLESS SPECIFIED)	
ANGULAR TOL ± 0.5 °	
4 PLACES	± ---
3 PLACES	± 0.005
2 PLACES	± 0.13
1 PLACE	± 0.25
0 PLACES	± ---

REVISION: <b>E2</b>	ECR/ECN INFORMATION: ECM No: <b>610323</b> DATE: <b>01/11/2019</b>	<b>MX150 MAT SEAL / UNSEALED RECEPTACLE APPLICATION SPECIFICATION</b>		SHEET No. <b>13 of 24</b>
DOCUMENT NUMBER: <b>AS-33012-002</b>		CREATED BY: <b>A.Proffitt</b>	CHECKED BY: <b>A.Dhir</b>	APPROVED BY: <b>T.Smith</b>



**Figure 16**

The insulation punch (top), and insulation anvil (bottom) are shown for Grip Codes 14 only.

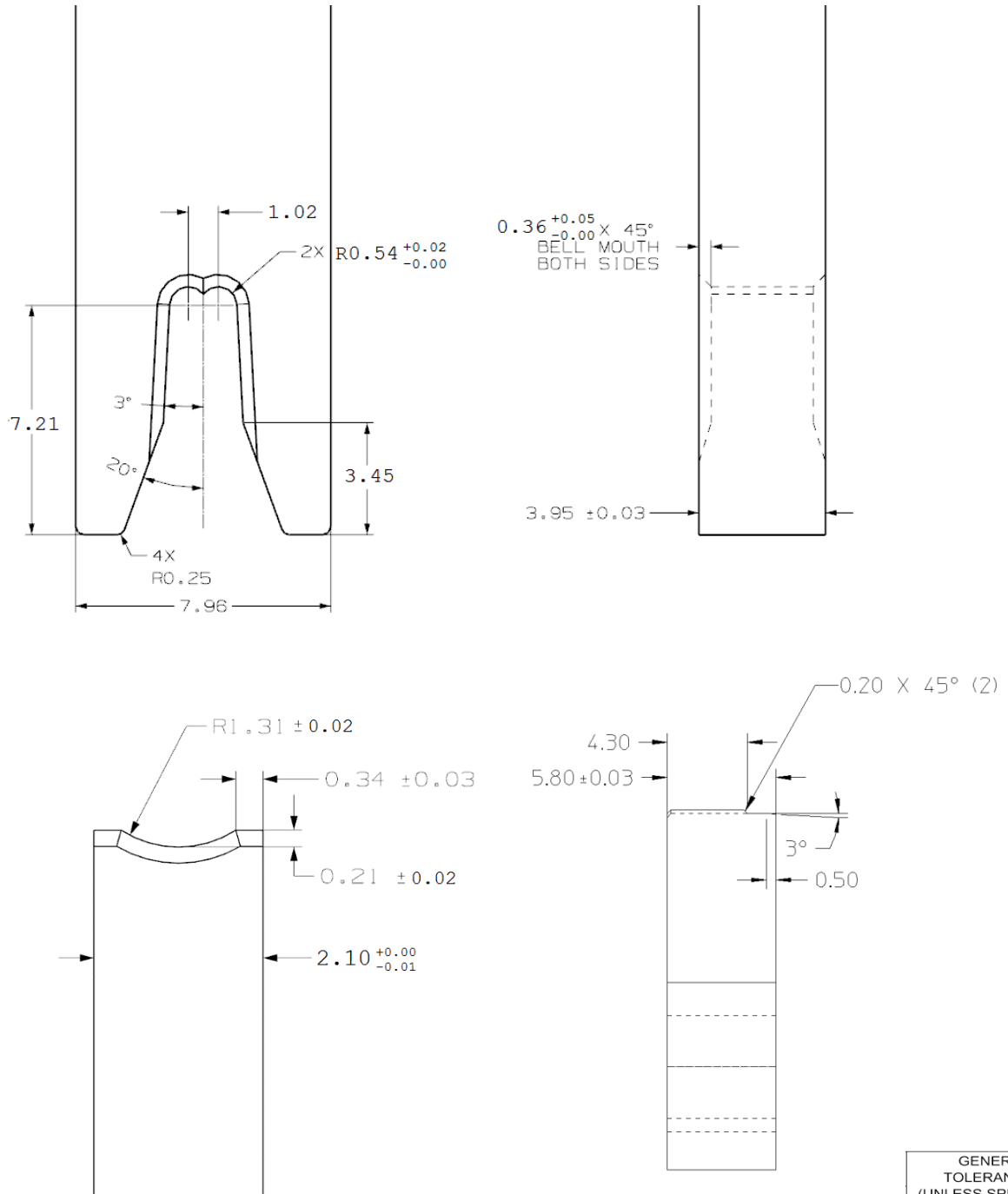
GENERAL TOLERANCES (UNLESS SPECIFIED)

ANGULAR TOL ± 0.5 °

Grip Code	Size SAE/Metric	Dim W ±0.13	Dim X ±0.13	Dim Y ±0.13
14	16 / 1.50	12.96	3.13	6.71
	14 / 2.00	13.12	3.06	6.25

4 PLACES	±	---
3 PLACES	±	0.005
2 PLACES	±	0.13
1 PLACE	±	0.25
0 PLACES	±	---

REVISION: <b>E2</b>	ECR/ECN INFORMATION: ECM No: 610323 DATE: 01/11/2019	<b>MX150 MAT SEAL / UNSEALED RECEPTACLE APPLICATION SPECIFICATION</b>		SHEET No. <b>14 of 24</b>
DOCUMENT NUMBER: <b>AS-33012-002</b>	CREATED BY: <b>A.Proffitt</b>	CHECKED BY: <b>A.Dhir</b>	APPROVED BY: <b>T.Smith</b>	

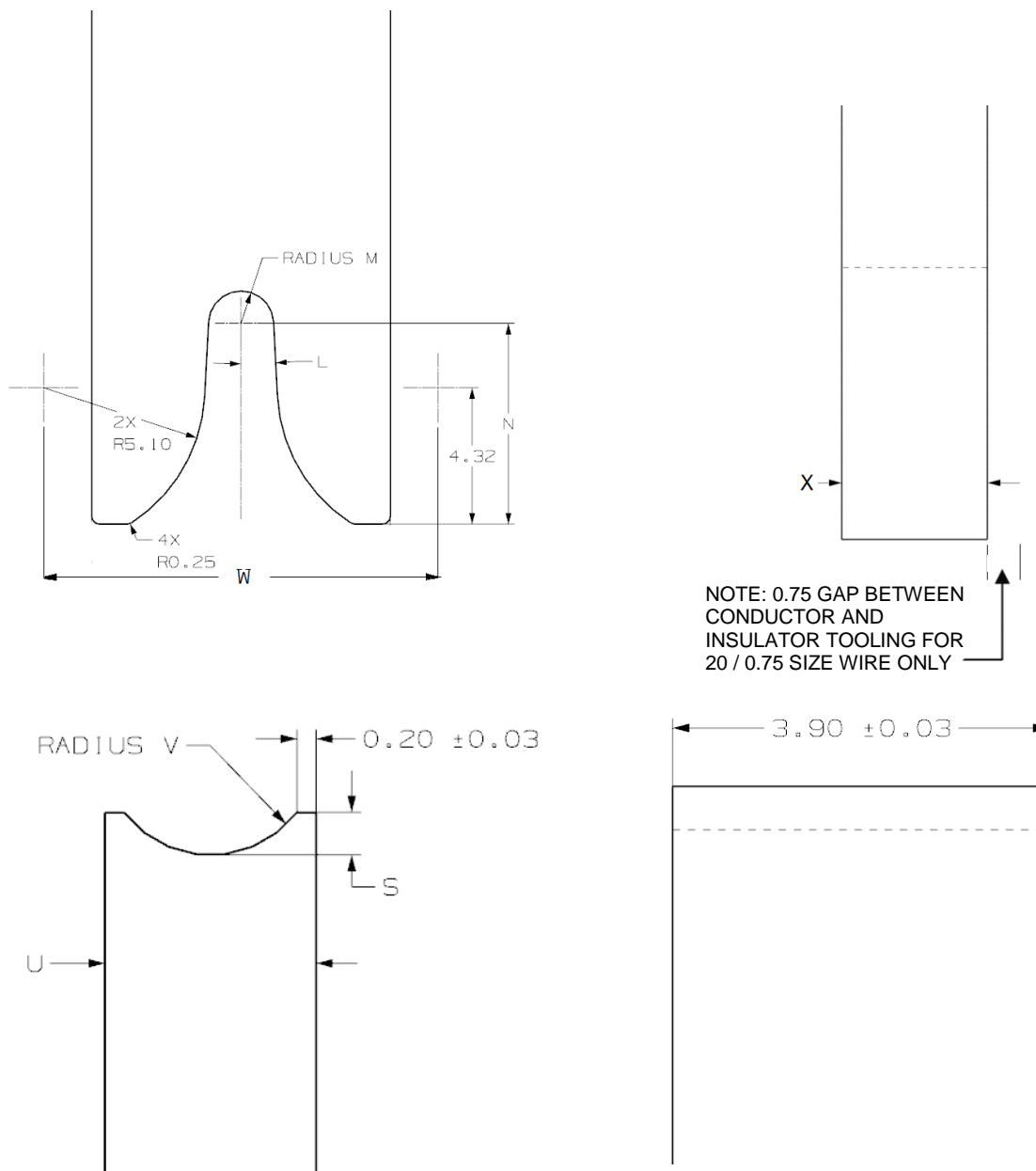


**Figure 17**

The conductor punch (top), and conductor anvil (bottom) are shown for Grip Code 18 only.

GENERAL TOLERANCES (UNLESS SPECIFIED)	
ANGULAR TOL ± 0.5 °	
4 PLACES	± ---
3 PLACES	± 0.005
2 PLACES	± 0.13
1 PLACE	± 0.25
0 PLACES	± ---

REVISION: <b>E2</b>	ECR/ECN INFORMATION: ECM No: <b>610323</b> DATE: <b>01/11/2019</b>	<b>MX150 MAT SEAL / UNSEALED RECEPTACLE APPLICATION SPECIFICATION</b>		SHEET No. <b>15 of 24</b>
DOCUMENT NUMBER: <b>AS-33012-002</b>	CREATED BY: <b>A.Proffitt</b>	CHECKED BY: <b>A.Dhir</b>	APPROVED BY: <b>T.Smith</b>	



**Figure 18**

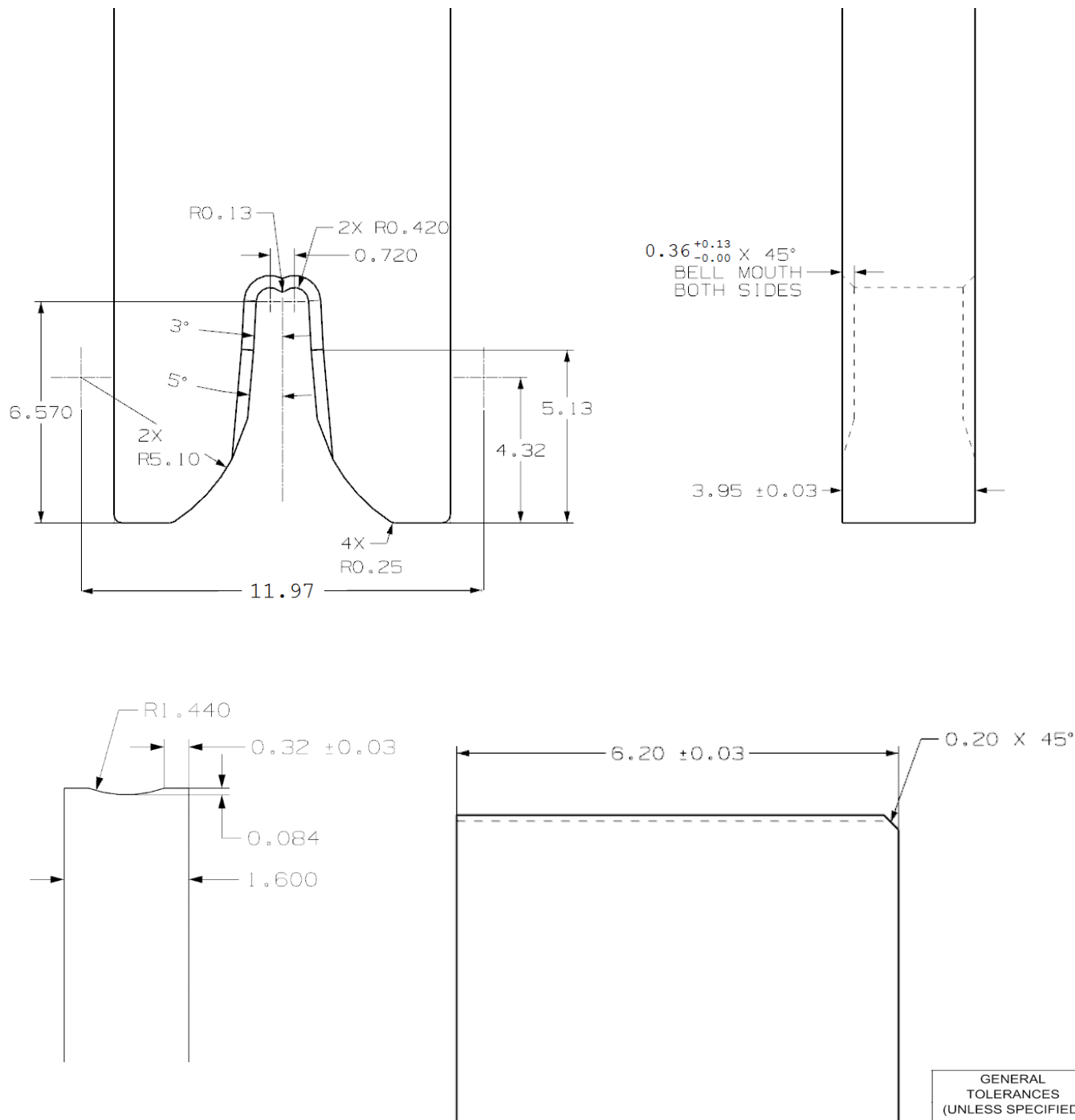
The insulation punch (top), and insulation anvil (bottom) are shown for Grip Code 18 only.

GENERAL TOLERANCES (UNLESS SPECIFIED)	
ANGULAR TOL ± 0.5 °	
4 PLACES	± ---
3 PLACES	± 0.005
2 PLACES	± 0.13
1 PLACE	± 0.25
0 PLACES	± ---

Grip Code	Size SAE/Metric	Dim W ±0.13	Dim X ±0.03
18	20 / 0.75	12.49	3.20
	18 / 1.00	12.70	3.95

REVISION: <b>E2</b>	ECR/ECN INFORMATION: ECM No: <b>610323</b> DATE: <b>01/11/2019</b>	<b>MX150 MAT SEAL / UNSEALED RECEPTACLE APPLICATION SPECIFICATION</b>		SHEET No. <b>16 of 24</b>
DOCUMENT NUMBER: <b>AS-33012-002</b>	CREATED BY: <b>A.Proffitt</b>	CHECKED BY: <b>A.Dhir</b>	APPROVED BY: <b>T.Smith</b>	



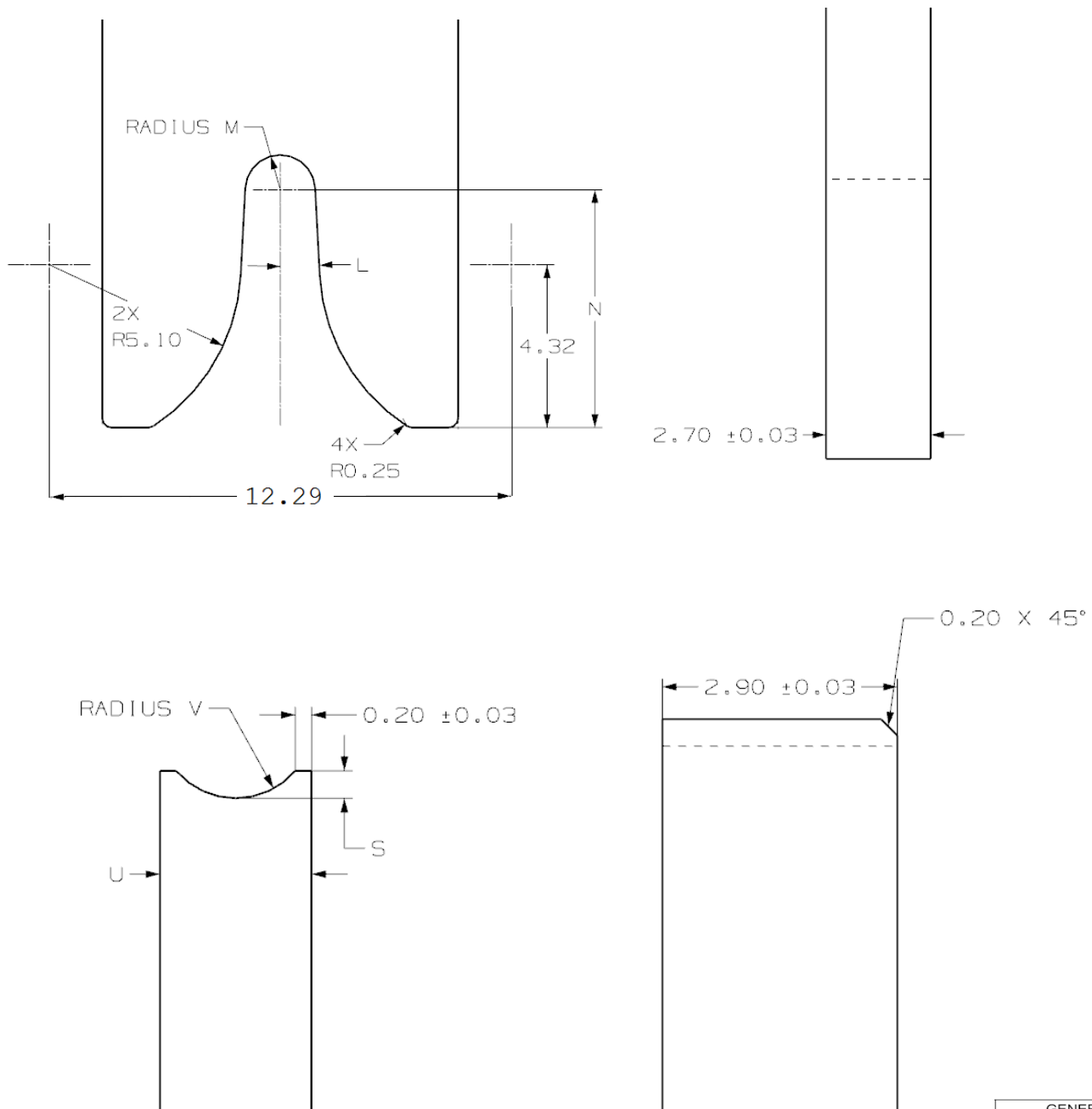


**Figure 19**

The conductor punch (top), and conductor anvil (bottom) are shown for Grip Code 22 only.

GENERAL TOLERANCES (UNLESS SPECIFIED)	
ANGULAR TOL	± 0.5 °
4 PLACES	± ---
3 PLACES	± 0.005
2 PLACES	± 0.13
1 PLACE	± 0.25
0 PLACES	± ---

REVISION: <b>E2</b>	ECR/ECN INFORMATION: ECM No: <b>610323</b> DATE: <b>01/11/2019</b>	<b>MX150 MAT SEAL / UNSEALED RECEPTACLE APPLICATION SPECIFICATION</b>		SHEET No. <b>17 of 24</b>
DOCUMENT NUMBER: <b>AS-33012-002</b>		CREATED BY: <b>A.Proffitt</b>	CHECKED BY: <b>A.Dhir</b>	APPROVED BY: <b>T.Smith</b>

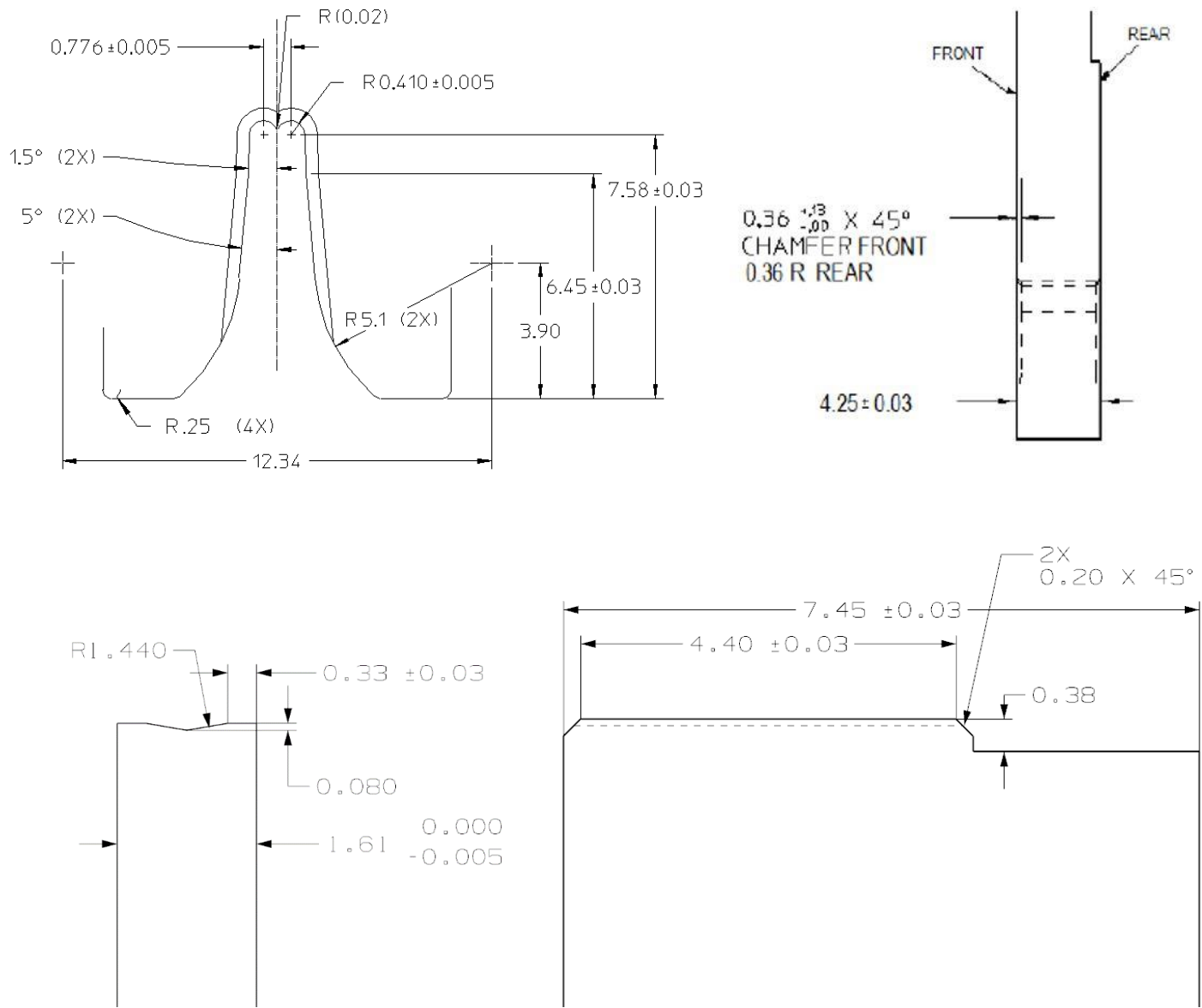


**Figure 20**

The insulation punch (top), and insulation anvil (bottom) are shown for Grip Code 22 only.

GENERAL TOLERANCES (UNLESS SPECIFIED)	
ANGULAR TOL ± 0.5 °	
4 PLACES	± ---
3 PLACES	± 0.005
2 PLACES	± 0.13
1 PLACE	± 0.25
0 PLACES	± ---

REVISION: <b>E2</b>	ECR/ECN INFORMATION: ECM No: <b>610323</b> DATE: <b>01/11/2019</b>	<b>MX150 MAT SEAL / UNSEALED RECEPTACLE APPLICATION SPECIFICATION</b>		SHEET No. <b>18 of 24</b>
DOCUMENT NUMBER: <b>AS-33012-002</b>		CREATED BY: <b>A.Proffitt</b>	CHECKED BY: <b>A.Dhir</b>	APPROVED BY: <b>T.Smith</b>

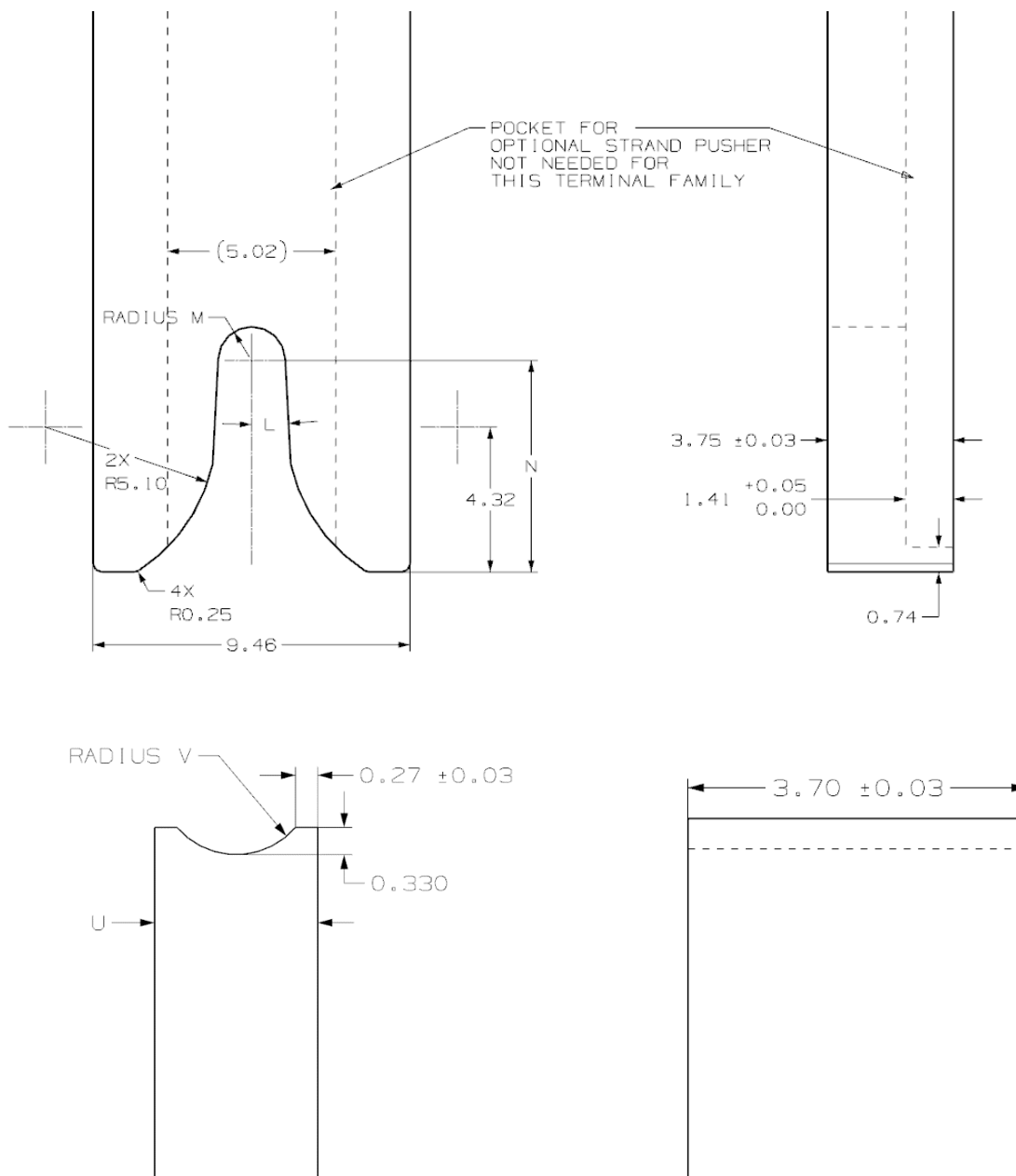


**Figure 21**

The conductor punch (top), and conductor anvil (bottom) are shown for Grip Code M3 only

GENERAL TOLERANCES (UNLESS SPECIFIED)	
ANGULAR TOL ± 0.5 °	
4 PLACES	± ---
3 PLACES	± 0.005
2 PLACES	± 0.13
1 PLACE	± 0.25
0 PLACES	± ---

REVISION: <b>E2</b>	ECR/ECN INFORMATION: ECM No: <b>610323</b> DATE: <b>01/11/2019</b>	<b>MX150 MAT SEAL / UNSEALED RECEPTACLE APPLICATION SPECIFICATION</b>		SHEET No. <b>19 of 24</b>
DOCUMENT NUMBER: <b>AS-33012-002</b>	CREATED BY: <b>A.Proffitt</b>	CHECKED BY: <b>A.Dhir</b>	APPROVED BY: <b>T.Smith</b>	



**Figure 22**

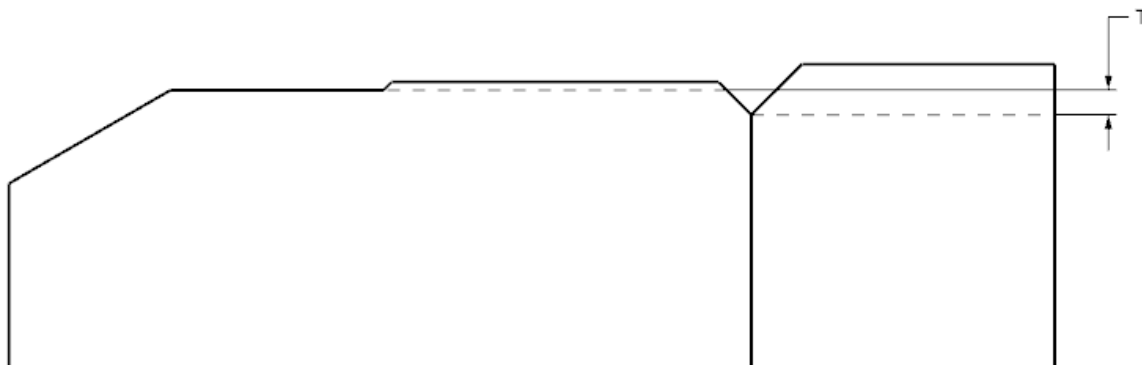
The insulation punch (top), and insulation anvil (bottom) are shown for Grip Code M3 only

GENERAL TOLERANCES (UNLESS SPECIFIED)	
ANGULAR TOL ± 0.5 °	
4 PLACES	± ---
3 PLACES	± 0.005
2 PLACES	± 0.13
1 PLACE	± 0.25
0 PLACES	± ---

REVISION: <b>E2</b>	ECR/ECN INFORMATION: ECM No: <b>610323</b> DATE: <b>01/11/2019</b>	<b>MX150 MAT SEAL / UNSEALED RECEPTACLE APPLICATION SPECIFICATION</b>		SHEET No. <b>20 of 24</b>
DOCUMENT NUMBER: <b>AS-33012-002</b>	CREATED BY: <b>A.Proffitt</b>	CHECKED BY: <b>A.Dhir</b>	APPROVED BY: <b>T.Smith</b>	

## 6.1 GENERAL CRIMP TOOLING GEOMETRY

The crimp tooling information shown on the following pages defines the tooling used by Molex to perform validation testing, to establish recommended crimp height and widths. The user is responsible for validating crimp performance based on tooling, equipment and wire that is being used.



**Figure 23**

(Side view of conductor and insulation anvil assembly)  
The anvil step (T) can be found in Table 4.

**Table 4 – Tooling Dimensions**

See Figures 15 – 23 for geometry

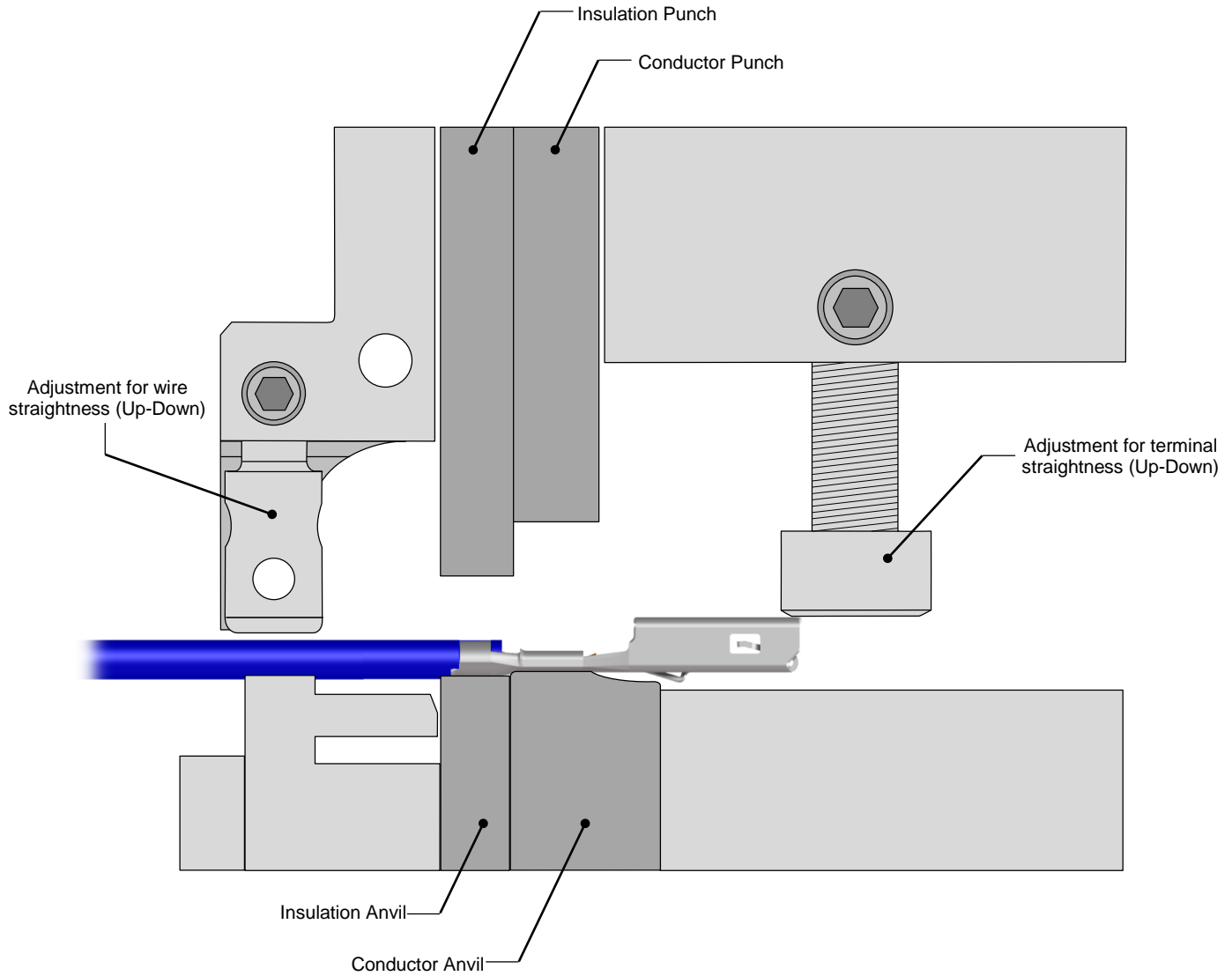
GRIP CODE	WIRE APPLICATION		L ±0.5°	M +0.03 -0.00	N ±0.03	S ±0.03	T ----	U +0.00 -0.03	V ±0.05
	SAE	METRIC							
M3	N/A	0.35–0.50 ①	3°	1.00±0.005	6.31±0.005	0.330±0.005	0.15	1.98±0.005	0.95±0.005
22	22	0.35–0.50 ②	3°	0.93	6.31	0.333±0.005	0.00	1.84±0.005	0.95±0.005
18	20 ③	0.75	3°	1.03	6.36	0.40	0.30	2.04	1.05
	20 (GXL)	N/A	3°	1.13	6.45	0.45	0.30	2.23	1.15
	18 ③	1.00	3°	1.13	6.45	0.45	0.30	2.23	1.15
	18 (GXL)	N/A	3°	1.28±0.005	6.50±0.005	0.55	0.30	2.52+0/-0.02	1.30±0.005
14	16	1.50	3°	1.28±0.005	6.50±0.005	0.55	0.30	2.52+0/-0.02	1.30±0.005
	14 (UTX)	1.25 AVSS	3°	1.28±0.005	6.50±0.005	0.55	0.30	2.52+0/-0.02	1.30±0.005
	14 ④	2.00 1.25 AVS	4°	1.30±0.005	6.63±0.005	0.62	0.30	2.70+0/-0.02	1.40±0.005

- ① For use in sealed applications only
- ② For use in unsealed applications only
- ③ Except GXL wire
- ④ Except UTX wire

REVISION: <b>E2</b>	ECR/ECN INFORMATION: ECM No: <b>610323</b> DATE: <b>01/11/2019</b>	<b>MX150 MAT SEAL / UNSEALED RECEPTACLE APPLICATION SPECIFICATION</b>		SHEET No. <b>21 of 24</b>
DOCUMENT NUMBER: <b>AS-33012-002</b>		CREATED BY: <b>A.Proffitt</b>	CHECKED BY: <b>A.Dhir</b>	APPROVED BY: <b>T.Smith</b>

**7.0 CRIMP STRAIGHTNESS**

A sample method for maintaining crimp straightness is shown in Figure 24 below.



**Figure 24**

<p>REVISION: <b>E2</b></p>	<p>ECR/ECN INFORMATION: ECM No: <b>610323</b> DATE: <b>01/11/2019</b></p>	<p><b>MX150 MAT SEAL / UNSEALED RECEPTACLE APPLICATION SPECIFICATION</b></p>	<p>SHEET No. <b>22 of 24</b></p>
<p>DOCUMENT NUMBER: <b>AS-33012-002</b></p>	<p>CREATED BY: <b>A.Proffitt</b></p>		<p>CHECKED BY: <b>A.Dhir</b></p>

## 8.0 APPLICATION TOOLING

Application tooling for the terminals can be obtained directly from Molex.

To find the proper and latest Molex Application Tooling

1. Go to <http://www.molex.com>
2. Enter the terminal / connector part number into the search box and select the “Go” button.
  - a. Molex part numbers can also be found by searching on the product description.
3. Review the Application Tooling available on the right side of the product window.
  - a. It may be necessary to scroll down on the right side of the terminal / connector product page to view all the tooling options.
  - b. Hand tools and manual type tools require the loose terminal / connector part number to be used in the search.
  - c. Applicator or semi-automatic type tools require the reeled terminal / connector part number to be used in the search.
4. Select the tool part number link
5. Review the tooling page for general tool information
6. Open the link for the Application Tooling Specification (ATS) (located on the left under *Specifications & Other Documents*) for additional details such as:
  - a. Termination specifications: crimp height, pull force, wire strip length, insulation diameter, etc.
  - b. Tool information: tool diagram, tool parts list, repair parts, perishable parts list.
7. Order Molex Application Tooling through your preferred distributor

Notes:

1. Hand crimp tooling can only be used with certain wires and terminal part numbers. Check the Application Tooling Specification Sheet on the Molex website for details.
2. Application Tooling product numbers are subject to change without prior notice. Customers are advised to check the Molex website for the most up-to-date information.
3. Molex FineAdjust™ and MiniMac™ Application Tooling requires the use of left payoff (“D” Wind) parts.

REVISION: <b>E2</b>	ECR/ECN INFORMATION: ECM No: <b>610323</b> DATE: <b>01/11/2019</b>	<b>MX150 MAT SEAL / UNSEALED RECEPTACLE APPLICATION SPECIFICATION</b>		SHEET No. <b>23 of 24</b>
DOCUMENT NUMBER: <b>AS-33012-002</b>		CREATED BY: <b>A.Proffitt</b>	CHECKED BY: <b>A.Dhir</b>	APPROVED BY: <b>T.Smith</b>



# APPLICATION SPECIFICATION

## Application Spec Revision Log

Change	By	Date	Revision Number
Included FLR91X and AVS wire sizes in Table 2. Updated 20 AWG tooling geometry.	J.Burgio	08/11/2016	C1
Adding PSA wires and Exrad Blocked and Exrad Unblocked in Table 2	F. Petit-Pierre	09/16/2016	D
Corrected location of cut-off tab arrow, Figure 2. Relabeled datum targets in Figure 4 to match datum target shown in Figure 11a. Relabeled datum target in Figure 5 to align datum target in Figure 4. Relocated datum J line to clarify insulation grip step (below datum J) in Figure 11a. Added figure 11b to show visual of insulator grip step of 22 grip code after the crimping process. Relabeled M3 grip code Figure 11b to 11c, Updated M3 grip code conductor punch geometry (reduced punch width & replaced chamfer with a radius on rear side), Figure 21. Updated dimension T for 18 & 22 grip code & dimension U for 14 & 16 SAE to match crimping tooling, Table 4.	Nvenkateshsh	07/06/2017	E
Added 0.50mm <sup>2</sup> and 1.25mm <sup>2</sup> JASO D611 AESSXf in Table 2	A. Proffitt	05/02/2018	E1
Added 0.75mm <sup>2</sup> JASO D611 AESSXf in Table 2	A. Proffitt	01/11/2019	E2

REVISION: <b>E2</b>	ECR/ECN INFORMATION: ECM No: <b>610323</b> DATE: <b>01/11/2019</b>	<b>MX150 MAT SEAL / UNSEALED RECEPTACLE APPLICATION SPECIFICATION</b>		SHEET No. <b>24 of 24</b>
DOCUMENT NUMBER: <b>AS-33012-002</b>	CREATED BY: <b>A.Proffitt</b>	CHECKED BY: <b>A.Dhir</b>	APPROVED BY: <b>T.Smith</b>	