



# PRODUCT SPECIFICATION



## MX64 Sealed Connector System Product specification

Circuit size: 1x2, 1x3, 1x6

Engineering series: 31402(34975), 31403(34977), 31404

|   |   |   |  |
|---|---|---|--|
| REVISION:<br><b>G2</b>                  | ECR/ECN INFORMATION:<br>EC No: <b>UAU2017-0225</b><br>DATE: <b>2026/01/09</b> | TITLE:<br><b>31402 CONNECTOR SYSTEM<br/>MX64 SINGLE ROW</b> | SHEET No.<br><b>1 of 10</b>              |
| DOCUMENT NUMBER:<br><b>PS-31402-000</b> | CREATED / REVISED BY:<br><b>Manish K Gowda</b>                                | CHECKED BY:<br><b>Mario Gazca</b>                           | APPROVED BY:<br><b>Enrique Dominquez</b> |



# PRODUCT SPECIFICATION

## Table of Contents

|       |   |    |
|-------|---|----|
| 1.0   | SCOPE .....   | 3  |
| 2.0   | PRODUCT DESCRIPTION .....                           | 3  |
| 2.1   | PRODUCT NAME AND SERIES NUMBER .....                | 3  |
| 2.2   | DIRECT CONNECTION (WIRE TO BOARD APPLICATION) ..... | 3  |
| 2.3   | RECEPTICAL ASSEMBLY .....                           | 4  |
| 2.4   | RECEPTICAL TERMINALS .....                          | 4  |
| 2.5   | DIMENSIONS, MATERIALS, PLATINGS AND MARKINGS .....  | 4  |
| 2.6   | ASSOCERIES .....                                    | 4  |
| 2.6.1 | WIRE DRESS COVER .....                              | 4  |
| 2.7   | SAFETY AGENCY APPROVALS .....                       | 4  |
| 3.0   | APPLICABLE DOCUMENTS AND SPECIFICATIONS .....       | 5  |
| 4.0   | RATINGS .....                                       | 5  |
| 4.1   | VOLTAGE .....                                       | 5  |
| 4.1.1 | OPERATING VOLTAGE .....                             | 5  |
| 4.1.2 | ISOLATION RESISTANCE VOLTAGE .....                  | 5  |
| 4.2   | CURRENT AND APPLICABLE WIRES .....                  | 5  |
| 4.3   | TEMPERATURE .....                                   | 5  |
| 4.4   | FLAMMABILITY .....                                  | 5  |
| 4.5   | VIBRATION .....                                     | 5  |
| 4.6   | SEALING .....                                       | 5  |
| 5.0   | PERFORMANCE .....                                   | 6  |
| 5.1   | ELECTRICAL PERFORMANCE .....                        | 6  |
| 5.2   | TEMPERATURE PERFORMANCE .....                       | 6  |
| 5.3   | MECHANICAL PERFORMANCE .....                        | 7  |
| 5.4   | MECHANICAL PERFORMANCE DEVIATIONS .....             | 8  |
| 5.5   | ENVIROMENTAL PERFORMANCE .....                      | 9  |
| 5.6   | SEALING PERFORMANCE .....                           | 10 |
| 6.0   | PACKAGING .....                                     | 10 |
| 7.0   | GAGES AND FIXTURES .....                            | 10 |
| 8.0   | OTHER INFORMATION .....                             | 10 |
| 9.0   | REVISIONS LOG .....                                 | 10 |

|   |   |   |  |
|---|---|---|--|
| REVISION:<br><b>G2</b>                  | ECR/ECN INFORMATION:<br>EC No: UAU2017-0225<br>DATE: 2026/01/09 | TITLE:<br><b>31402 CONNECTOR SYSTEM<br/>MX64 SINGLE ROW</b> | SHEET No.<br><b>2 of 10</b>              |
| DOCUMENT NUMBER:<br><b>PS-31402-000</b> | CREATED / REVISED BY:<br><b>Manish K Gowda</b>                  | CHECKED BY:<br><b>Mario Gazca</b>                           | APPROVED BY:<br><b>Enrique Dominquez</b> |



# PRODUCT SPECIFICATION

## 1.0 SCOPE

This product specification defines the product performance of the MX64 sealed connector system. The MX64 system is based on USCAR EWCAP 64-S-00\* interface for 0.64 mm width terminal. The system has a 2.54 mm terminal spacing (pitch), single row, specifically for direct connection (wire to board) applications, terminated with 22 to 18 AWG wires or ISO 0.35mm to 0.75mm using crimp technology.

## 2.0 PRODUCT DESCRIPTION

### 2.1 PRODUCT NAME AND SERIES NUMBER

Refer to listed document number for part availability, dimensions, material, marking information, packaging information, interface definition, and configuration options etc.

| Product Name                   | Series        | Part Number         | Document Number                 |
|--------------------------------|---------------|---------------------|---------------------------------|
| 2 Way Female Assembly - GET    | 31402 / 34975 | 31402-2* / 34975-2* | SD-31402-211<br>(sales drawing) |
| 3 Way Female Assembly - GET    | 31402 / 34975 | 31402-3* / 34975-3* |                                 |
| 6 Way Female Assembly - GET    | 31402 / 34975 | 31402-6* / 34975-6* |                                 |
| 2 Way Female Assembly - MX64   | 31403 / 34977 | 31403-2* / 34977-2* |                                 |
| 3 Way Female Assembly - MX64   | 31403 / 34977 | 31403-3* / 34977-3* |                                 |
| 6 Way Female Assembly - MX64   | 31403 / 34977 | 31403-6* / 34977-6* |                                 |
| 3 Way Female Assembly - Kaizen | 31404         | 31404-3*            |                                 |
| 6 Way Female Assembly - Kaizen | 31404         | 31404-6*            |                                 |

\* All part numbers associated with the series above are controlled by this document. For specific part information relating to Polarization, CPA & Cavity Void Pattern refer to sales drawing above

### 2.2 DIRECT CONNECTION (WIRE TO BOARD APPLICATION)

1x2 example below is representative for 1x3 & 1x6 circuits, all engineering series

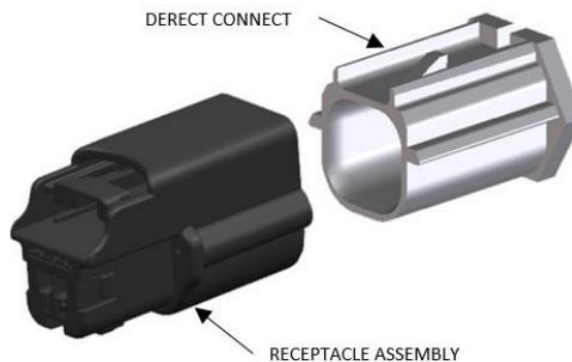

|   |   |   |  |
|---|---|---|--|
| REVISION:<br><b>G2</b>                  | ECR/ECN INFORMATION:<br>EC No: <b>UAU2017-0225</b><br>DATE: <b>2026/01/09</b> | TITLE:<br><b>31402 CONNECTOR SYSTEM<br/>MX64 SINGLE ROW</b> | SHEET No.<br><b>3 of 10</b>              |
| DOCUMENT NUMBER:<br><b>PS-31402-000</b> | CREATED / REVISED BY:<br><b>Manish K Gowda</b>                                | CHECKED BY:<br><b>Mario Gazca</b>                           | APPROVED BY:<br><b>Enrique Dominquez</b> |



# PRODUCT SPECIFICATION

## 2.3 RECEPTICAL ASSEMBLY

1x2 example below is representative for 1x3 & 1x6 circuits, all engineering series

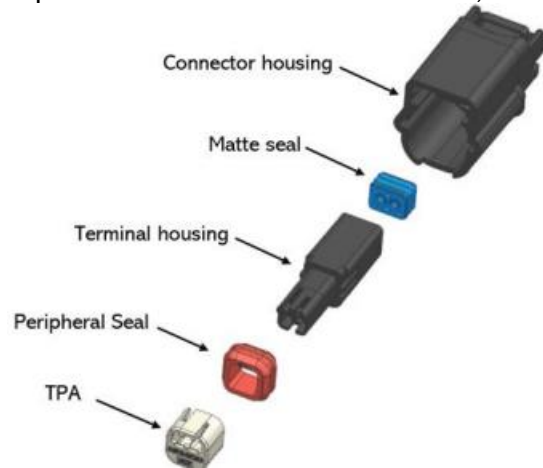

## 2.4 RECEPTICAL TERMINALS

Refer to application specification defined in section 3.0 for validate terminals

## 2.5 DIMENSIONS, MATERIALS, PLATINGS AND MARKINGS

- Connector Housing: 15% glass filled PBT
- Terminal Housing: 30% glass filled SPS/nylon blend
- TPAs: 20% glass filled SPS/nylon blend
- CPAs: 30% glass filled PBT
- Seals: Inherently lubricated silicone

## 2.6 ASSOCERIES

### 2.6.1 WIRE DRESS COVER

| Product name                           | Part number | Document number |
|--|-------------|-----------------|
| MX64 2 WAY WIRE DRESS COVER (VERTICAL) | 31413-2600  | 314132600       |

\*Note: Wire dress cover restricted for Ford related to 34975 and 34977 series.

## 2.7 SAFETY AGENCY APPROVALS

|                    |                |
|--------------------|----------------|
| UL File Number     | Not Applicable |
| CSA File Number    | Not Applicable |
| TUV License number | Not Applicable |

|   |   |   |  |
|---|---|---|--|
| REVISION:<br><b>G2</b>                  | ECR/ECN INFORMATION:<br>EC No: <b>UAU2017-0225</b><br>DATE: <b>2026/01/09</b> | TITLE:<br><b>31402 CONNECTOR SYSTEM<br/>MX64 SINGLE ROW</b> | SHEET No.<br><b>4 of 10</b>              |
| DOCUMENT NUMBER:<br><b>PS-31402-000</b> | CREATED / REVISED BY:<br><b>Manish K Gowda</b>                                | CHECKED BY:<br><b>Mario Gazca</b>                           | APPROVED BY:<br><b>Enrique Dominquez</b> |



# PRODUCT SPECIFICATION

## 3.0 APPLICABLE DOCUMENTS AND SPECIFICATIONS

| Description                            | Document Number  |
|--|--|
| 2-6 way female sales drawing (charted) | SD-31402-211   |
| Packaging specification (bulk)         | PK-31300-256   |
| Application specification              | AS-31402-000   |
| Interface specification                | USCAR - EWCAP --><br>064-S-002-1-Z02(2CKT)<br>064-S-003-1-Z01(3CKT)<br>064-S-006-1-Z02(6CKT) |
| Performance specification              | USCAR 2 rev. 4   |

## 4.0 RATINGS

### 4.1 VOLTAGE

#### 4.1.1 OPERATING VOLTAGE

20 Volts DC Maximum

#### 4.1.2 ISOLATION RESISTANCE VOLTAGE

100MΩ Minimum when 500 Volts DC between adjacent terminals and terminals to ground.

### 4.2 CURRENT AND APPLICABLE WIRES

Current is dependant on connector size, ambient temperature, blade size and related factors. Actual maximum current rating is application dependent and should be evaluated for each use.

| ISO (AWG)         | Amperes | Wire range Insulation Diameter      |
|-------------------|---------|-------------------------------------|
| 0.35mm (22 gauge) | 8.6A    | 1.20 - 1.65 mm (0.059 - 0.065 inch) |
| 0.5mm (20 gauge)  | 10A     | 1.70 - 1.85 mm (0.067 - 0.073 inch) |
| 0.75mm (18 gauge) | 11.3A   | 1.91 - 2.06 mm (0.075 - 0.081 inch) |

### 4.3 TEMPERATURE

Operating: - 40 C° to + 125 C° (Temperature class 3 per USCAR 2 rev 4)  
NON-OPERATING: - 40 C° to + 125 C°

### 4.4 FLAMMABILITY

All molded components are flammability rated UL94 HB and are also compliant to FM VSS 302 and the corresponding ISO 3795 with a limited horizontal burning rate of <100 mm/min at test specimen wall thickness >= 1mm

### 4.5 VIBRATION

Vibration class 2 per USCAR2 rev 4 for Engine profile, typically used for components coupled to engine with no sever vibration.

### 4.6 SEALING

Sealing class 2 per USCAR2 rev 4 without wire dress cover  
Sealing class 3 with wire dress cover

|   |   |   |  |
|---|---|---|--|
| REVISION:<br><b>G2</b>                  | ECR/ECN INFORMATION:<br>EC No: <b>UAU2017-0225</b><br>DATE: <b>2026/01/09</b> | TITLE:<br><b>31402 CONNECTOR SYSTEM<br/>MX64 SINGLE ROW</b> | SHEET No.<br><b>5 of 10</b>              |
| DOCUMENT NUMBER:<br><b>PS-31402-000</b> | CREATED / REVISED BY:<br><b>Manish K Gowda</b>                                | CHECKED BY:<br><b>Mario Gazca</b>                           | APPROVED BY:<br><b>Enrique Dominquez</b> |



# PRODUCT SPECIFICATION

## 5.0 PERFORMANCE

### 5.1 ELECTRICAL PERFORMANCE

| ITEM | DESCRIPTION                                       | TEST CONDITION  | REQUIREMENT                                      |
|------|---|---|--|
| 1    | Contact Resistance (Low Level)                    | Mate connectors: limiting the open circuit voltage of 20 mV and a maximum current of 100 mA.  | 20 milliohms<br>MAXIMUM                          |
| 2    | Contact Resistance @ Rated Current (Voltage Drop) | Mate connectors: apply a 5 ampere/ 1.0 mm <sup>2</sup> current  | 20 milliohms<br>MAXIMUM                          |
| 3    | Isolation Resistance                              | Apply a voltage of 500 VDC between adjacent terminals and between terminals to ground.  | 20 Meg ohms<br>MINIMUM                           |
| 4    | Temperature Rise (via Current Cycling)            | Mate terminals: measure the temperature rise at the rated current after: 1008 hours of bench top testing (45 minutes ON and 15 minutes OFF per hour). | Temperature rise over Ambient:<br>+55 C° MAXIMUM |

### 5.2 TEMPERATURE PERFORMANCE

| Circuit Size      | Operating Conditions | Wire Range     | Designed to Mate with | Recommended Wire Type* | Recommended Terminal Plating Type |
|-------------------|----------------------|----------------|-----------------------|------------------------|-----------------------------------|
| 1X2<br>1X3<br>1X6 | Temperature Class 3  | 1.20 - 2.06 mm | Direct Connect        | TXL                    | Sn                                |

|   |   |   |  |
|---|---|---|--|
| REVISION:<br><b>G2</b>                  | ECR/ECN INFORMATION:<br>EC No: UAU2017-0225<br>DATE: 2026/01/09 | TITLE:<br><b>31402 CONNECTOR SYSTEM<br/>MX64 SINGLE ROW</b> | SHEET No.<br><b>6 of 10</b>              |
| DOCUMENT NUMBER:<br><b>PS-31402-000</b> | CREATED / REVISED BY:<br><b>Manish K Gowda</b>                  | CHECKED BY:<br><b>Mario Gazca</b>                           | APPROVED BY:<br><b>Enrique Dominquez</b> |



# PRODUCT SPECIFICATION

## 5.3 MECHANICAL PERFORMANCE

| ITEM | DESCRIPTION  | TEST CONDITION   | REQUIREMENT                |
|------|--|--|----------------------------|
| 5    | Connector Mate/<br>Unmate Forces                                 | Mate and unmate connector (male to female) at a rate of $50 \pm 6$ mm ( $2 \pm \frac{1}{4}$ inch) per minute.  | 75 Newtons MAXIMUM         |
|      |  |  | Unmate 110 Newtons MINIMUM |
| 6    | Terminal Retention Force (in Housing)                            | Axial pullout force on the terminal in the housing at a rate of $50 \pm 6$ mm ( $2 \pm \frac{1}{4}$ inch) per minute. With primary and secondary lock        | 75 Newtons MINIMUM         |
| 7    | Terminal Retention Force (in Housing)                            | Axial pullout force on the terminal in the housing at a rate of $50 \pm 6$ mm ( $2 \pm \frac{1}{4}$ inch) per minute. Without secondary lock                 | 30 Newtons MINIMUM         |
| 8    | Terminal Insertion Force (into Housing)                          | Apply an axial insertion force on the terminal at a rate of $50 \pm 6$ mm ( $2 \pm \frac{1}{4}$ inch) per minute.  | 30 Newtons MAXIMUM         |
| 9    | Connector Audible Feedback                                       | The connector lock must provide audible feedback during connector mating at a rate of $50 \pm 6$ mm ( $2 \pm \frac{1}{4}$ inch) per minute.                  | 7dB over Ambient (C scale) |
| 10   | Polarization Feature Effectiveness                               | Connector must be polarized to prevent mating with similar connectors or incorrect orientation   | 220 Newtons MINIMUM        |
| 11   | Terminal Position Assurance (TPA) Insertion Force (into housing) | The force to insert the TPA from the preload (as shipped) position to the final position at a rate of $50 \pm 6$ mm ( $2 \pm \frac{1}{4}$ inch) per minute.  | 60 Newtons MAXIMUM         |
| 12   | Terminal Position Assurance (TPA) Extraction Force (in housing)  | The force to extract the TPA from the final position to the preload position (as shipped) at a rate of $50 \pm 6$ mm ( $2 \pm \frac{1}{4}$ inch) per minute. | 60 Newtons MAXIMUM         |
| 13   | Connector Position Assurance (CPA) Extraction Force (removal)    | The force to completely remove the CPA from the final position at a rate of $50 \pm 6$ mm ( $2 \pm \frac{1}{4}$ inch) per minute.                            | 30 Newtons MINIMUM         |

|   |   |   |  |
|---|---|---|--|
| REVISION:<br><b>G2</b>                  | ECR/ECN INFORMATION:<br>EC No: UAU2017-0225<br>DATE: 2026/01/09 | TITLE:<br><b>31402 CONNECTOR SYSTEM<br/>MX64 SINGLE ROW</b> | SHEET No.<br><b>7 of 10</b>              |
| DOCUMENT NUMBER:<br><b>PS-31402-000</b> | CREATED / REVISED BY:<br><b>Manish K Gowda</b>                  | CHECKED BY:<br><b>Mario Gazca</b>                           | APPROVED BY:<br><b>Enrique Dominquez</b> |



# PRODUCT SPECIFICATION

## 5.4 MECHANICAL PERFORMANCE DEVIATIONS

For circuit sizes not mentioned in section 5.4 no deviation required

| ITEM | DESCRIPTION   | TEST CONDITION   | REQUIREMENT  |
|------|---|--|--|
| 14   | <b>Terminal Position Assurance (TPA) removal force</b>                                      | The force to extract the TPA from the preload position (as shipped) to remove from housing at a rate of $50 \pm 6$ mm ( $2 \pm \frac{1}{4}$ inch) per minute.                  | <b>ONLY for 1X2 &amp; 1X3</b><br><b>15 Newtons MINIMUM</b><br>USCAR2 rev4 requires 25N MINIMUM               |
| 15   | <b>Terminal Position Assurance (TPA) Extraction Force 2<sup>nd</sup> cycle (in housing)</b> | The force to extract the TPA from the final position to the preload position (as shipped) on a second cycle at a rate of $50 \pm 6$ mm ( $2 \pm \frac{1}{4}$ inch) per minute. | <b>ONLY for 1X2</b><br><b>11 Newtons MINIMUM</b><br>USCAR2 rev4 requires 18N MINIMUM                         |
|      |   |  | <b>ONLY for 1X3</b><br><b>9 Newtons MINIMUM</b><br>USCAR2 rev4 requires 18N MINIMUM                          |
| 16   | <b>Connector Position Assurance (CPA) Insertion Force (into housing)</b>                    | The force to insert the CPA from the preload (as shipped) position to the final position at a rate of $50 \pm 6$ mm ( $2 \pm \frac{1}{4}$ inch) per minute.                    | <b>ONLY for 1X2</b><br><b>55 Newtons MINIMUM</b><br>USCAR2 rev4 requires 60N MINIMUM (unmated)               |
|      |   |  | <b>ONLY for 1X3 &amp; 1X6</b><br><b>50 Newtons MINIMUM</b><br>USCAR2 rev4 requires 60N MINIMUM (unmated)     |
| 17   |   |  | <b>ONLY for 1X2 &amp; 1X3</b><br><b>28 Newtons MAXIMUM</b><br>USCAR2 rev4 requires 22N MAXIMUM (fully mated) |
|      |   |  | <b>ONLY for 1X6</b><br><b>38 Newtons MAXIMUM</b><br>USCAR2 rev4 requires 22N MAXIMUM (fully mated)           |
| 18   | <b>Connector Position Assurance (CPA) Extraction Force (in housing)</b>                     | The force to extract the CPA from the final position to the preload (as shipped) position at a rate of $50 \pm 6$ mm ( $2 \pm \frac{1}{4}$ inch) per minute.                   | <b>ONLY for 1X2</b><br><b>30 Newtons MAXIMUM</b><br>USCAR2 rev4 requires >10N and ≤30N                       |
|      |   |  | <b>ONLY for 1X3</b><br><b>45 Newtons MAXIMUM</b><br>USCAR2 rev4 requires >10N and ≤30N                       |
|      |   |  | <b>ONLY for 1X6</b><br><b>40 Newtons MAXIMUM</b><br>USCAR2 rev4 requires >10N and ≤30N                       |

|   |   |   |  |
|---|---|---|--|
| REVISION:<br><b>G2</b>                  | ECR/ECN INFORMATION:<br>EC No: <b>UAU2017-0225</b><br>DATE: <b>2026/01/09</b> | TITLE:<br><b>31402 CONNECTOR SYSTEM<br/>MX64 SINGLE ROW</b> | SHEET No.<br><b>8 of 10</b>              |
| DOCUMENT NUMBER:<br><b>PS-31402-000</b> | CREATED / REVISED BY:<br><b>Manish K Gowda</b>                                | CHECKED BY:<br><b>Mario Gazca</b>                           | APPROVED BY:<br><b>Enrique Dominquez</b> |



# PRODUCT SPECIFICATION

## 5.5 ENVIROMENTAL PERFORMANCE

| ITEM                  | DESCRIPTION                              | TEST CONDITION   | REQUIREMENT   |                           |           |    |            |    |  |
|-----------------------|--|--|---|---------------------------|-----------|----|------------|----|--|
| 18                    | Field Correlated Life Test (FCLT)        | Mate connectors up to 1 cycle and expose to environment per SAE/USCAR-20.  | 20 milliohms MAXIMUM  |                           |           |    |            |    |  |
| 19                    | Durability                               | Mate connectors up to 10 cycles prior to environmental tests.  | 20 milliohms MAXIMUM & Discontinuity < 1 microsecond  |                           |           |    |            |    |  |
| 20                    | Thermal Shock (Electrical)               | Mate connectors per durability; expose to 100 cycles of:<br><table border="1" style="margin-left: 20px;"> <tr> <td><u>Temperature C°</u></td> <td><u>Duration (Minutes)</u></td> </tr> <tr> <td>-40 +0/-3</td> <td>30</td> </tr> <tr> <td>+125 +3/-0</td> <td>30</td> </tr> </table> | <u>Temperature C°</u>   | <u>Duration (Minutes)</u> | -40 +0/-3 | 30 | +125 +3/-0 | 30 | 20 milliohms MAXIMUM & Discontinuity < 1 microsecond |
| <u>Temperature C°</u> | <u>Duration (Minutes)</u>                |  |   |                           |           |    |            |    |  |
| -40 +0/-3             | 30                                       |  |   |                           |           |    |            |    |  |
| +125 +3/-0            | 30                                       |  |   |                           |           |    |            |    |  |
| 21                    | High Temperature Exposure (Sealing)      | Mate connectors per durability and expose to 1008 hours at 125 ± 2°C   | 28 kPa for 15 seconds MINIMUM pressure/vacuum & Submersion for 30 minutes & Isolation Resistance of 20 Meg ohms @ 500 VDC MINIMUM |                           |           |    |            |    |  |
| 22                    | Temperature/ Humidity (Sealing)          | Mate connectors per durability and expose connector system to forty 8-hour cycles of combined heating and humidity exposure -40 °C and 125 °C at 0% to 90% RH  | 28 kPa for 15 seconds MINIMUM pressure/vacuum & Submersion for 30 minutes & Isolation Resistance of 20 Meg ohms @ 500 VDC MINIMUM |                           |           |    |            |    |  |
| 23                    | Fluid Resistance (Sealing)               | Submerge connector assemblies in the following fluids: gasoline, *diesel fuel, engine oil, ethanol, power steering fluid, automatic transmission fluid, engine coolant, and brake fluid.   | Submersion for 30 minutes & Isolation Resistance of 20 Meg ohms @ 500 VDC MINIMUM   |                           |           |    |            |    |  |
| 24                    | Vibration/ Mechanical Shock (Electrical) | Mate connectors per durability. Connector assembly shall be vibrated for (8 hours / axes @ 12.1 Grms, 10 shocks @ 35 Gs / axes) Coupled to engine.   | 20 milliohms MAXIMUM & Discontinuity < 1 microsecond  |                           |           |    |            |    |  |

\*Silicone seals swell in the presence of diesel fuel. This condition may cause excessive connector mate/unmate forces.

|   |   |   |  |
|---|---|---|--|
| REVISION:<br><b>G2</b>                  | ECR/ECN INFORMATION:<br>EC No: UAU2017-0225<br>DATE: 2026/01/09 | TITLE:<br><b>31402 CONNECTOR SYSTEM<br/>MX64 SINGLE ROW</b> | SHEET No.<br><b>9 of 10</b>              |
| DOCUMENT NUMBER:<br><b>PS-31402-000</b> | CREATED / REVISED BY:<br><b>Manish K Gowda</b>                  | CHECKED BY:<br><b>Mario Gazca</b>                           | APPROVED BY:<br><b>Enrique Dominquez</b> |



# PRODUCT SPECIFICATION

## 5.6 SEALING PERFORMANCE

| Circuit Size | Operating Conditions   | Wire Range     | Designed to Mate with | Recommended Wire Type* |
|--------------|--|----------------|-----------------------|------------------------|
| 1X2          | Temperature Class 3<br>Sealing: Pressure/<br>Vacuum Leak and<br>Submersion Post<br>Environment Condition | 1.20 - 2.06 mm | Direct<br>Connect     | TXL                    |
| 1X3          |  |                |                       |                        |
| 1X6          |  |                |                       |                        |

\*Must be compliant to the wire specifications listed in section 4.2

## 6.0 PACKAGING

- Parts shall be packaged to protect against damage during handling, transit and storage.
- TPAs may become seated during transit, please refer to PS-34646-001 for more information.
- Molex packaging drawing numbers are located on the Assembly Drawing listed in section 3.0
- Packaging validated under *ISTA 3F Test Procedure for Packaged Products*.

## 7.0 GAGES AND FIXTURES

All applicable gages and fixtures are referenced in the appropriate control plans.

## 8.0 OTHER INFORMATION

Products conform to USCAR-2 class III environment.

## 9.0 REVISIONS LOG

| REVISION | DESCRIPTION  |
|----------|--|
| G2       | BOOK MARK ISSUE FIXED IN APPENDIX  |
| G1       | 4.2 ADD ISO WIRES AND INCREASING WIRE OD RANGE FROM 1.5MM TO 1.2MM<br>5.3 ADD MECHANICAL DEVIATIONS CHART<br>4.4 FLAMMABILITY INFORMATION UPDATE<br>CREATE REVISIONS LOG CHART |
| G        | UAU2017-0225   |
| F        | UAU2016-0391   |
| E        | UAU2014-1659   |
| D        | UAU2014-0247   |
| B        | UAU2012-1479   |
| A        | RELEASE - UAU2008-0220   |

MOLEX REPRESENTS AND WARRANTS TO BUYER FOR A PERIOD OF ONE (1) YEAR FROM THE DATE OF DELIVERY OF THE PRODUCTS TO BUYER THAT

- 1) THE PRODUCTS SHALL CONFORM TO THE MOLEX SPECIFICATIONS FOR THE PRODUCTS IN FORCE AT THE DATE OF DELIVERY OF THE PRODUCTS TO BUYER, AND
- 2) THE PRODUCTS SHALL BE OF FREE FROM MATERIAL DEFECTS IN MATERIALS AND MANUFACTURING.

EXCEPT AS EXPRESSLY PROVIDED ABOVE, MOLEX MAKES NO WARRANTY, EXPRESS OR IMPLIED, REGARDING THE PRODUCTS. ALL IMPLIED WARRANTIES, INCLUDING, BUT NOT LIMITED TO, THE IMPLIED WARRANTIES OF FITNESS FOR A PARTICULAR PURPOSE, ARE HEREBY DISCLAIMED. IN ADDITION, MOLEX EXPRESSLY DISCLAIMS ANY WARRANTY OBLIGATIONS IN THOSE INSTANCES WHERE THE FAILURES RESULTED FROM THE MODIFICATION OF THE PRODUCTS BY BUYER OR ITS CUSTOMERS, IMPROPER HANDLING, USE OR INSTALLATION OF THE PRODUCTS BY BUYER OR ITS CUSTOMERS, OR ANY OTHER CAUSE BEYOND THE CONTROL OF MOLEX.

|   |   |   |  |
|---|---|---|--|
| REVISION:<br><b>G2</b>                  | ECR/ECN INFORMATION:<br>EC No: <b>UAU2017-0225</b><br>DATE: <b>2026/01/09</b> | TITLE:<br><b>31402 CONNECTOR SYSTEM<br/>MX64 SINGLE ROW</b> | SHEET No.<br><b>10 of 10</b>             |
| DOCUMENT NUMBER:<br><b>PS-31402-000</b> | CREATED / REVISED BY:<br><b>Manish K Gowda</b>                                | CHECKED BY:<br><b>Mario Gazca</b>                           | APPROVED BY:<br><b>Enrique Dominquez</b> |