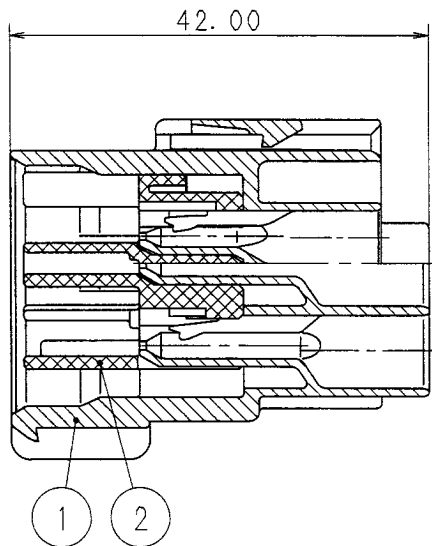
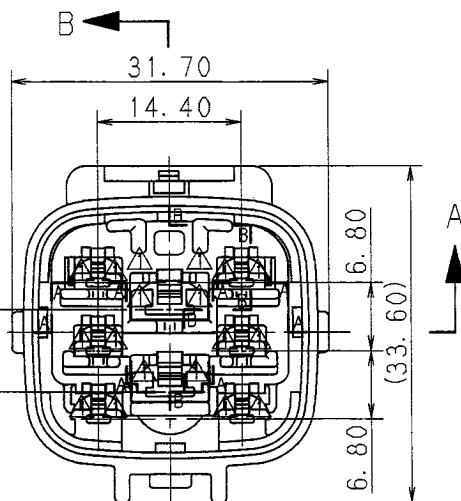

TABLE 1

SUB ASSEMBLY PART NO.	NO.	PART NO.	MATERIAL	COLOR	QTY.
7282-7081-10 ETC.	①	SEE TABLE 2	PBT	SEE TABLE 2	1
	②	7157-4109	PBT	NATURAL	1

TABLE 2

SUB ASSEMBLY PART NO.	PART NO.	COLOR
△ 7282-7081, ㊦	7182-7081	NATURAL
7282-7081-10, ㊦	7182-7081-10	DARK GRAY
7282-7081-30, ㊦	7182-7081-30	BLACK
7282-7081-40, ㊦	7182-7081-40	LIGHT GRAY
△ 7282-7081-50, ㊦	7182-7081-50	ORANGE
△ 7282-7081-60, ㊦	7182-7081-60	GREEN
△ 7282-7081-80, ㊦	7182-7081-80	BROWN
△ 7282-7081-90, ㊦	7182-7081-90	BLUE



SEC. B-B

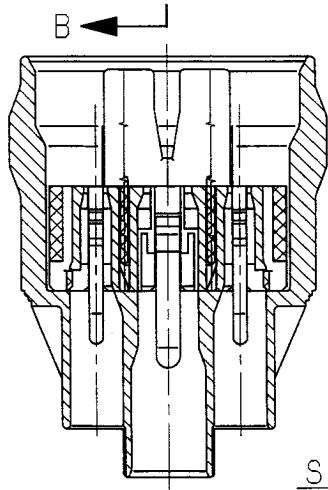

SEC. A-A

注記

- 1. 適用端子番 : 090II 7114-4025 ETC.
187 7114-4035 ETC.
- 2. 嵌合相手番 : 7283-7081-30 ETC.

NOTES

- 1. APPLICABLE TERMINAL PART NO. :
090II 7114-4025 ETC.
187 7114-4035 ETC.
- 2. MATING PART NO. : 7283-7081-30 ETC.

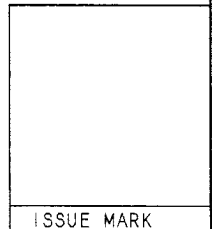

REVISION RECORD		GENERAL TOLERANCE			CUSTOMER				MATERIAL SPEC.		TREAT. & FIN.								
LET	DATE	NO.	CHKD	10MAX	50MAX	100MAX	250MAX	250OVR	ANGLE	ECCENT	DWG TYPE	DWG SOURCE	DWG DATE	UNIT	SCL	ANGLE	PART NO.	CH. CODE	SET DWG NO.
△	98.04.08	CHANGED FORM & ADDED COLOR NO., ㊦	C98-L669	S. S	±0.15	±0.2	±0.3	±0.5	±0.75	±30'	0.1	R	NEW	90.07.30	mm	2/1	3	7282-7081-10 ETC.	
	90.07.30	NEW	C90-L838	K. O	±0.2	±0.3	±0.55	±0.95	±1.4	±30'	0.1	APPROVED	CHECKED	CHECKED	DESIGN	DRAWN	7282-7081-10:R		
LET	DATE	REVISION RECORD	NO.	CHKD	VENDOR				VENDOR NO.				NAME 090II 6P + 187 2P HYBRID SEALED						
												CONNECTOR HOUSING MALE SUB ASSEMBLY							
												YAZAKI CORPORATION							
												YAZAKI CORPORATION							