

1

2

3

SUB ASSEMBLY PART NO. AND CH. CODE	NO.	PART NO. AND CH. CODE	MATERIAL	COLOR	QTY.
7282-8856-30, C, A	①	7182-8856-30	PBT	BLACK	1
	②	A 7158-5887	PBT	A NATURAL	1

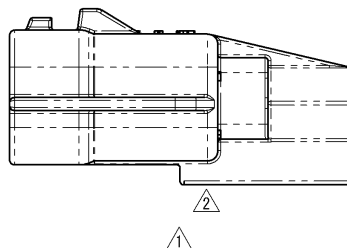
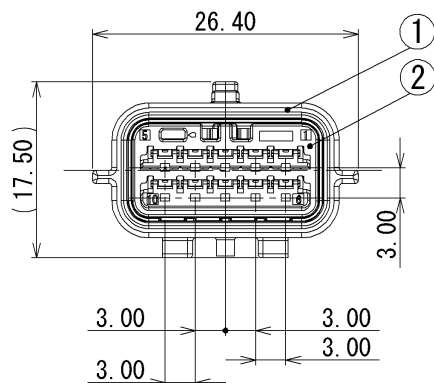
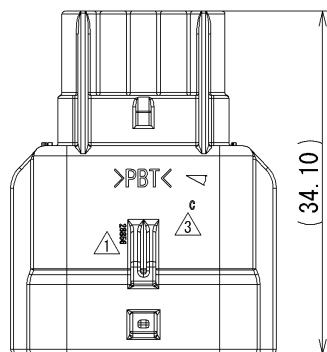

## NOTES

- MATING PART NO. : 7283-8856-30
- APPLICABLE TERMINAL NO. : 7114-4415-02 ETC.
- APPLICABLE SEAL RUBBER NO. : 7158-3165-90, 7158-3166-60, 7158-3167-80  
7158-3168-80
- APPLICABLE UNUSED CAVITY PLUG: 7158-3169-40

## 注記

- かん合相手品番 : 7283-8856-30
- 適用端子品番 : 7114-4415-02 ETC.
- 適用ゴム栓品番 : 7158-3165-90, 7158-3166-60, 7158-3167-80  
7158-3168-80
- 適用防水栓品番 : 7158-3169-40

REV.	DATE	REVISION RECORD	NO.	CHKD
A	10/11/15	CHANGED PART NAME	C10-ZA94	R. E
B	03/08/07	CHANGED CODE, C	C03-X324	T. Y
C	02/12/04	CHANGED FORM, B	C02-Y497	T. Y
D	02/01/31	ELIMINATE SECTION	C02-X210	T. Y
E	01/11/08	NEW	C01-Y135	T. Y

GENERAL TOLERANCE							
	10MAX	50MAX	100MAX	250MAX	2500VR	ANGLE	ECCENT
A	±0.15	±0.2	±0.3	±0.5	±0.75	±30'	0.1
B	±0.2	±0.3	±0.55	±0.95	±1.4	±30'	0.1
C	±0.3	±0.5	±0.8	±1.4	±2	±30'	0.15

LET	DATE	REVISION RECORD	NO.	CHKD

CUSTOMER		CUSTOMER PART NO.		CUSTOMER DWG NO.	
OFFICE		TRIAL PART NO.		VENDOR	
DWG TYPE		DWG SOURCE		DWG DATE	
R		NEW		01/11/08	
APPROVED	CHECKED	CHECKED	DESIGN	DRAWN	
S. MIZUSE		R. CABANGAL	M. KASHIYAMA	R. ESPITAL	
10/11/15		10/11/15	01/05/08	10/11/15	

MATERIAL SPEC.		SEE TABLE		TREAT. & FIN.	
NAME					
A RH TYPE HOUSING 10P					
SUB ASSEMBLY MALE					
PART NO. CH. CODE					
7282-8856-30, C, A					
DWG NO.		SET DRW NO.			
7282-8856-30:R					
YAZAKI CORPORATION					

1

2

3